

Service
Service
Service



Service Manual



TABLE OF CONTENTS

	Page
Location of PC Boards	1-2
Versions Variation & Package	1-2
Specifications	1-3
Measurement Setup	1-4
Service Aids	1-5
ESD & Safety Instruction	1-6
Setting Procedure & Repair Instructions	2
Disassembly Instructions & Service positions	3
Block & Wiring Diagram	4
Key/Video/Sensor/Phone/Vol /Vu Board	5
Tuner Board	6
Main Board	7
Power Board	8
Mechanical Exploded View & Parts List	11



© Copyright 2004 Philips Consumer Electronics B.V. Eindhoven, The Netherlands
All rights reserved. No part of this publication may be reproduced, stored in a retrieval system or transmitted, in any form or by any means, electronic, mechanical, photocopying, or otherwise without the prior permission of Philips.

Published by SL-ET0447 Service Audio Printed in The Netherlands Subject to modification.

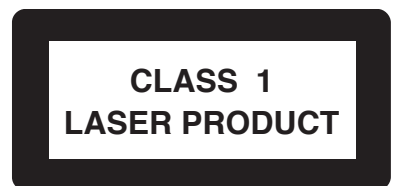

3141 785 30100

Version 1.0



PHILIPS

SPECIFICATIONS

AMPLIFIER SECTION

Output power	3300 W PMPO
Stereo mode (DIN)	100 W + 100 W RMS
Surround mode (1 kHz)	DIN OUT
Frequency Response	180 Hz - 14 kHz / \pm 3 dB
Signal-to-Noise Ratio	> 62dB (A-weighted)
AUX/TV In	500 mV

Output Sensitivity	
Headphone	800 mV – 1100 mV
Line Out	400 mV – 600 mV

TUNER SECTION

Tuning Range	FM 87.5 – 108 MHz (50 kHz steps)
.....	MW 531 – 1602 kHz (9 kHz steps)
.....	MW 530 – 1710 kHz (10 kHz steps)
26 dB Quieting Sensitivity	FM 20 dB
26 dB Quieting Sensitivity	MW 3162 mV/m
Image Rejection Radio	FM 25dB
.....	MW 28 dB
IF Rejection Ratio	FM 60 dB
.....	MW 24 dB
Signal-to-Noise Ratio	FM \geq 55 dB
.....	MW \geq 35 dB
MW Suppression Ratio	FM 30 dB
Harmonic Distortion	FM Mono 3 %
.....	FM Stereo 3 %
.....	MW 5 %
Frequency Response	FM 180 Hz – 10 kHz / \pm 6 dB
Stereo Separation	FM 26 dB (1 kHz)
Stereo Threshold	FM 23.5 dB

TAPE SECTION

Frequency Response	
Normal tape (type 1)	80 – 12500 Hz (8 dB)
Signal-to-Noise Ratio	
Normal tape (type 1)	\geq 46 dBA
Wow and flutter	\leq 0.4% DIN

DVD SECTION

Laser Type	Semiconductor
Disc Diameter	12cm / 8cm
Video Decoding	MPEG-2 / MPEG-1
Video DAC	10 Bits
Signal System	PAL / NTSC
Video Format	4:3 / 16:9
Video S/N	56 dB (minimum)
Composite Video Output	1.0 Vp-p, 75 Ω
S-Video Output	Y - 1.0 Vp-p, 75 Ω
.....	C - 0.286 Vp-p, 75 Ω
Audio DAC	24 Bits / 96 kHz
Frequency Response	4 Hz - 20 kHz (44.1kHz)
.....	4 Hz - 22 kHz (48kHz)

.....	4 Hz - 44 kHz (96kHz)
Digital Output	
.....	SPDIF (Sony Philips digital interface) Coaxial
PCM	IEC 60958
Dolby Digital/DTS	IEC 60958, IEC 61937

MAIN UNIT

Power Supply Rating	110 - 127 / 220 - 240V
.....	50 / 60 Hz Switchable
Power Consumption	
Active	110W
ECO Power Standby	< 1 W
Dimensions (w x h x d)	265x 322 x 354 (mm)
Weight	5.7 kg

SPEAKERS

Front speakers	
System	3-way, Bass reflex
Impedance	3 Ω
Speaker drivers	6.5" woofer,
.....	2" tweeter
Frequency response	50 Hz – 20 kHz
Dimensions (w x h x d)	242 x 310 x 240 (mm)
Weight	3.72 kg/each

Specifications and external appearance are subject to change without notice.

MEASUREMENT SETUP

Tuner FM

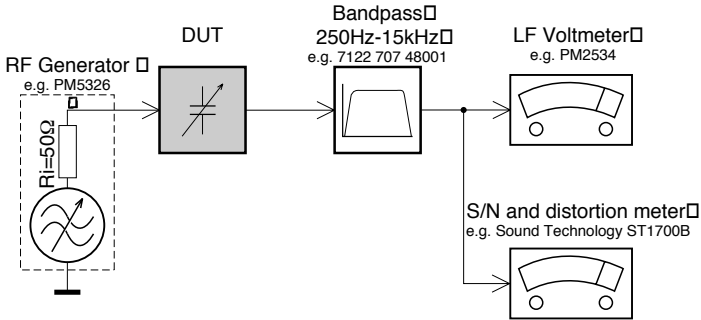

Use a bandpass filter to eliminate hum (50Hz, 100Hz) and disturbance from the pilotone (19kHz, 38kHz).

Tuner AM (MW,LW)

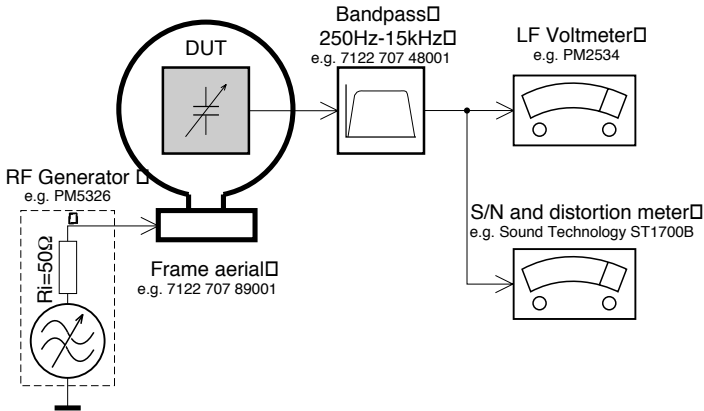

To avoid atmospheric interference all AM-measurements have to be carried out in a Faraday's cage. Use a bandpass filter (or at least a high pass filter with 250Hz) to eliminate hum (50Hz, 100Hz).

CD

Use Audio Signal Disc SBC429 4822 397 30184 (replaces test disc 3)

□

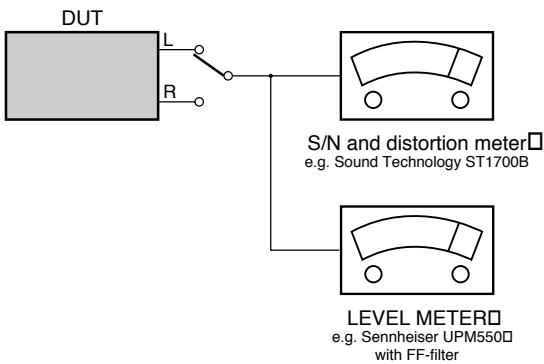

Recorder

Use Universal Test Cassette **CrO2** SBC419 4822 397 30069 or Universal Test Cassette **Fe** SBC420 4822 397 30071

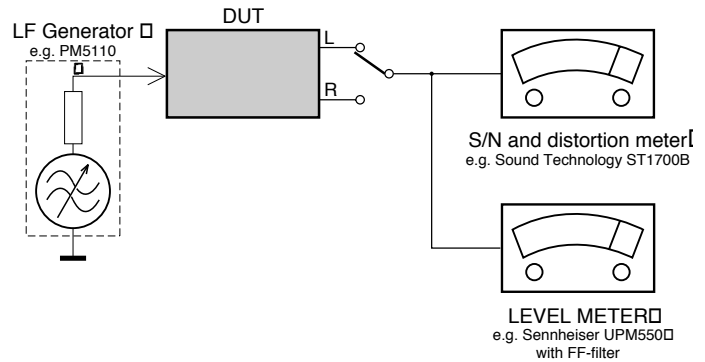

SERVICE AIDS

Service Tools:

Universal Torx driver holder	4822 395 91019
Torx bit T10 150mm	4822 395 50456
Torx driver set T6-T20	4822 395 50145
Torx driver T10 extended	4822 395 50423

Compact Disc:

SBC426/426A Test disc 5 + 5A	4822 397 30096
SBC442 Audio Burn-in test disc 1kHz	4822 397 30155
SBC429 Audio Signals disc	4822 397 30184
Dolby Pro-logic Test Disc	4822 395 10216

ESD Equipment:

Anti-static table mat - large 1200x650x1.25mm ...	4822 466 10953
anti-static table mat - small 600x650x1.25mm	4822 466 10958
Anti-static wristband	4822 395 10223
Connectorbox (1M Ω)	4822 395 11307
Extension cable	
(to connect wristband to conn.box)	4822 320 11305
Connecting cable	
(to connect table mat to conn.box)	4822 320 11306
Earth cable (to Connect product to mat or box) --	4822 320 11308
Complete kit ESD3	
(combining all above products)	4822 320 10671
Wristband tester	4822 344 13999

HANDLING CHIP COMPONENTS

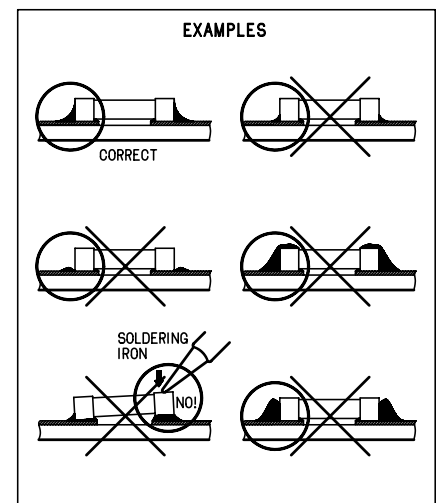
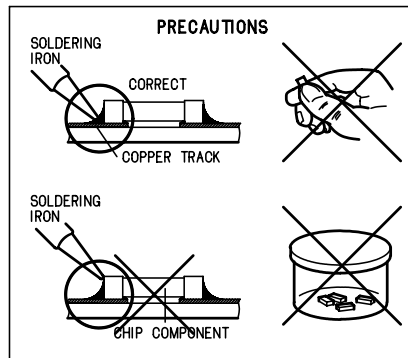
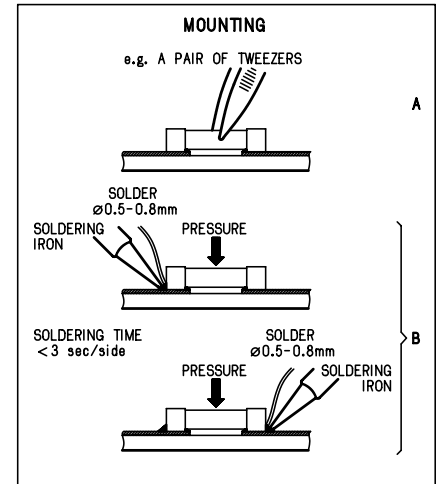
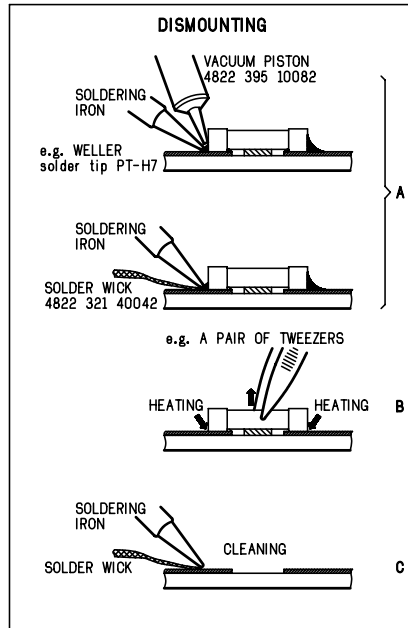
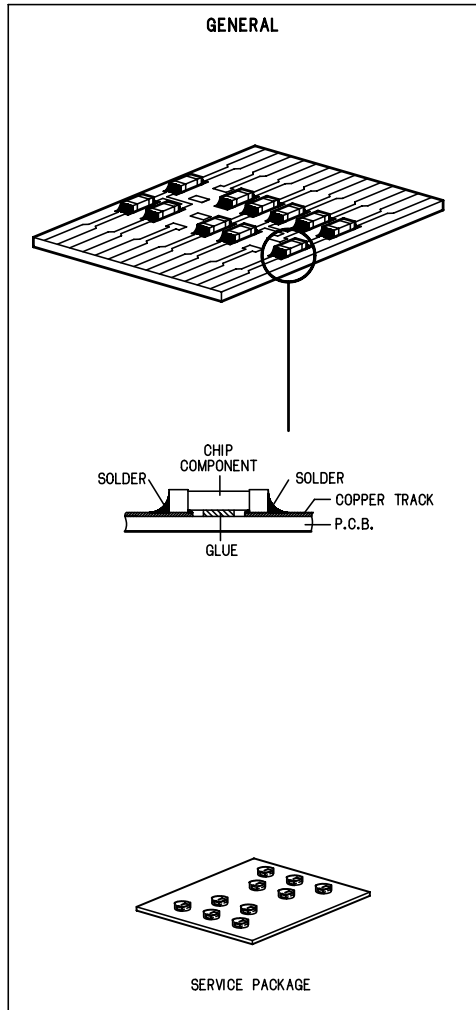

(GB) WARNING

All ICs and many other semi-conductors are susceptible to electrostatic discharges (ESD). Careless handling during repair can reduce life drastically.

When repairing, make sure that you are connected with the same potential as the mass of the set via a wrist wrap with resistance.

Keep components and tools also at this potential.

ESD**(NL) WAARSCHUWING**

Alle IC's en vele andere halfgeleiders zijn gevoelig voor electrostatische ontladingen (ESD).

Onzorgvuldig behandelen tijdens reparatie kan de levensduur drastisch doen verminderen. Zorg ervoor dat u tijdens reparatie via een polsband met weerstand verbonden bent met hetzelfde potentiaal als de massa van het apparaat.

Houd componenten en hulpmiddelen ook op hetzelfde potentiaal.

(F) ATTENTION

Tous les IC et beaucoup d'autres semi-conducteurs sont sensibles aux décharges statiques (ESD).

Leur longévité pourrait être considérablement écourtée par le fait qu'aucune précaution n'est prise à leur manipulation.

Lors de réparations, s'assurer de bien être relié au même potentiel que la masse de l'appareil et enfilez le bracelet serti d'une résistance de sécurité.

Veiller à ce que les composants ainsi que les outils que l'on utilise soient également à ce potentiel.

(D) WARNUNG

Alle ICs und viele andere Halbleiter sind empfindlich gegenüber elektrostatischen Entladungen (ESD).

Unvorsichtige Behandlung im Reparaturfall kann die Lebensdauer drastisch reduzieren.

Veranlassen Sie, dass Sie im Reparaturfall über ein Pulsarmband mit Widerstand verbunden sind mit dem gleichen Potential wie die Masse des Gerätes.

Bauteile und Hilfsmittel auch auf dieses gleiche Potential halten.

(I) AVVERTIMENTO

Tutti IC e parecchi semi-conduttori sono sensibili alle scariche statiche (ESD). La loro longevità potrebbe essere fortemente ridotta in caso di non osservazione della più grande cauzione alla loro manipolazione.

Durante le riparazioni occorre quindi essere collegato allo stesso potenziale che quello della massa dell'apparecchio tramite un braccialetto a resistenza.

Assicurarsi che i componenti e anche gli utensili con quali si lavora siano anche a questo potenziale.

(GB)

Safety regulations require that the set be restored to its original condition and that parts which are identical with those specified, be used.

"Pour votre sécurité, ces documents doivent être utilisés par des spécialistes agréés, seuls habilités à réparer votre appareil en panne".

(NL)

Veiligheidsbepalingen vereisen, dat het apparaat bij reparatie in zijn oorspronkelijke toestand wordt teruggebracht en dat onderdelen, identiek aan de gespecificeerde, worden toegepast.

**(F)**

Les normes de sécurité exigent que l'appareil soit remis à l'état d'origine et que soient utilisées les pièces de rechange identiques à celles spécifiées.

(GB) Warning !

Invisible laser radiation when open.
Avoid direct exposure to beam.

(D)

Bei jeder Reparatur sind die geltenden Sicherheitsvorschriften zu beachten. Der Originalzustand des Geräts darf nicht verändert werden; für Reparaturen sind Original-Ersatzteile zu verwenden.

(S) Varning !

Osynlig laserstrålning när apparaten är öppnad och spårren är urkopplad. Betrakta ej strålen.

(I)

Le norme di sicurezza esigono che l'apparecchio venga rimesso nelle condizioni originali e che siano utilizzati i pezzi di ricambio identici a quelli specificati.

(SF) Varoitus !

Avatussa laitteessa ja suojalukituksen ohitettaessa olet alltiina näkymättömälle laserisäteilylle. Älä katso säteeseen!

(DK) Advarse !

Usynlig laserstrålning ved åbning når sikkerhedsafbrydere er ude af funktion. Undgå udsættelse for stråling.

"After servicing and before returning set to customer perform a leakage current measurement test from all exposed metal parts to earth ground to assure no shock hazard exist. The leakage current must not exceed 0.5mA."

PREPARATIONS AND CONTROLS

Preparations

Notes:

- The clock will be cancelled when the power cord is disconnected or if a power failure occurs.
- During clock setting, if no button is pressed within 10 seconds, the system will exit the setting mode and go back to it's previous status.

Step 3: Setting the TV set

IMPORTANT!

- Make sure you have completed all the necessary connections. (See Connections - Connecting TV set)

1 Press **DISC (DISC 1+2+3)** on the front panel (or press **DISC 1/2/3** on the remote control).

2 Turn on the TV set and set to the correct Video-In channel. You should see the blue Philips DVD background screen on the TV set.

→ You may go to channel 1 on your TV set, then press the channel down button repeatedly until you see the Video In channel.

→ Or, you can use the TV remote control to select different video modes.

→ Or, set TV to channel 3 or 4 if you are using an RF modulator.

Selecting the color system that matches your TV set

This DVD Mini Hi-Fi System is compatible with both NTSC and PAL. For the playback of a DVD disc on this DVD Mini Hi-Fi System, the color systems of the DVD, TV set and DVD Mini Hi-Fi System should match.

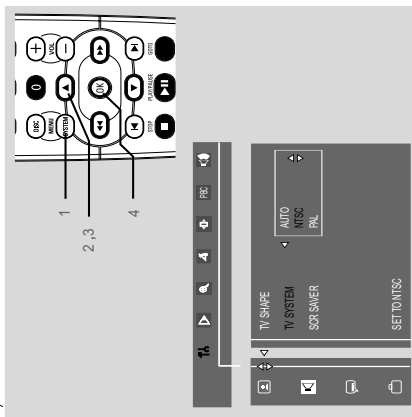

1 In disc mode, stop playback and press **SYSTEM MENU**.

2 Select **TV** icon and press **▼**.

3 Press **◀** / **▶** / **▲** / **▼** keys on the remote control to toggle through the functions and select your preferred option.

→ Move to **TV** and press **▶▶▶**.

→ Move to "TV System" and press **▶▶▶**.

AUTO

- Select this if the connected TV set is compatible with both NTSC and PAL (multi system). The output format will be consistent with the video signal of the disc.

NTSC

- Select this if the connected TV set is NTSC system. It will change the video signal of a PAL video disc and output to NTSC system.

PAL

- Select this if the connected TV set is PAL system. It will change the video signal of an NTSC disc and output to PAL format.

4 Select an item and press **OK**.

To remove the menu
Press **SYSTEM MENU**.

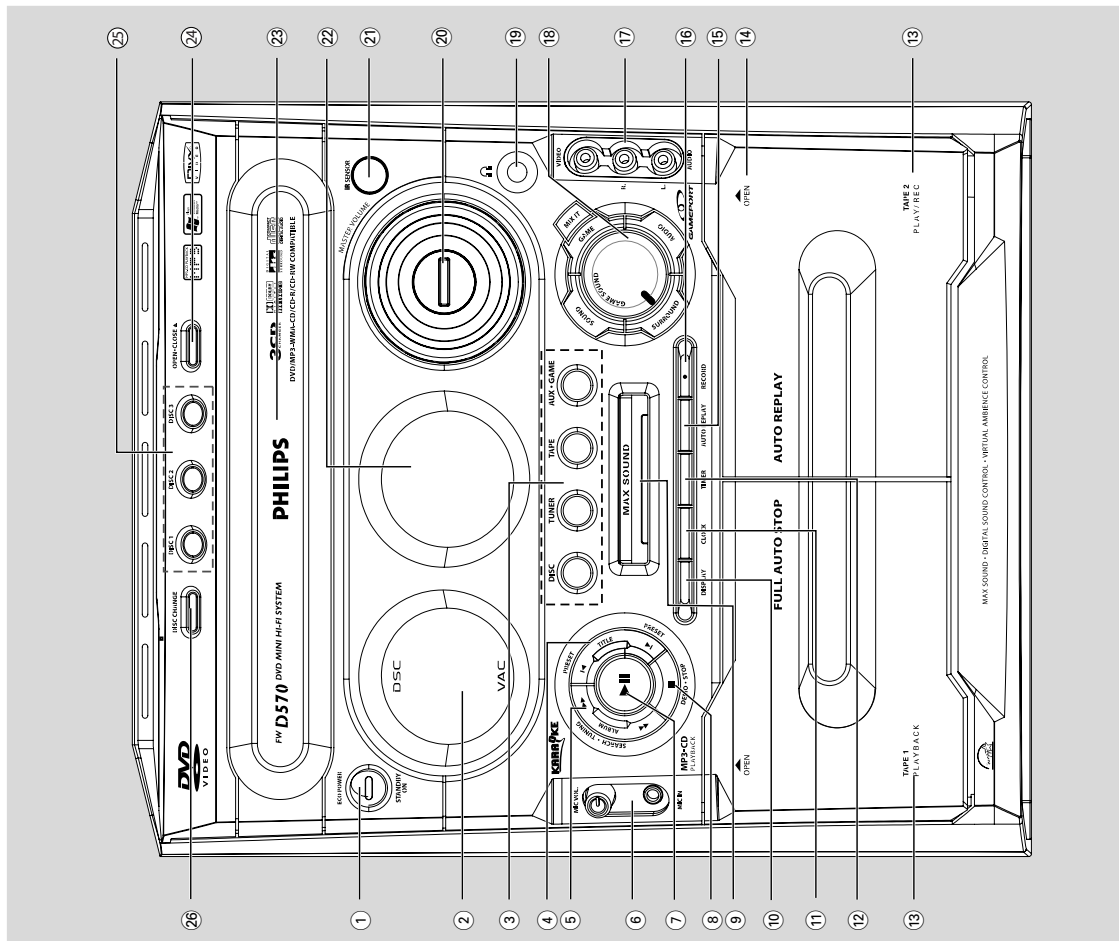

26 OPEN/CLOSE
25 VIDEO
24 AUDIO
23 DVD
22 DVD MINI HI-FI SYSTEM
21 PHILIPS
20 DVD MINI HI-FI SYSTEM
19 DSC
18 VAC
17 MAX SOUND
16 FULL AUTO
15 FULL AUTO (TOP)
14 AUTO REPLAY
13 TIME 1 PLAYBACK
TIME 2 PLAY/REC
MAX SOUND - DIGITAL SOUND CONTROL - VIRTUAL AMBIENCE CONTROL

Connections

Step 1: Placing speakers

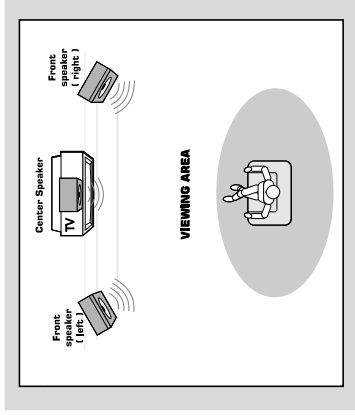

Place the front left and right speakers at equal distances from the TV set and at an angle of approximately 45 degrees from the listening position.

Notes:

- To avoid magnetic interference, do not position the front speakers too close to your TV set.
- Allow adequate ventilation around the DVD Mini Hi-Fi System.

Step 2: Connecting speakers

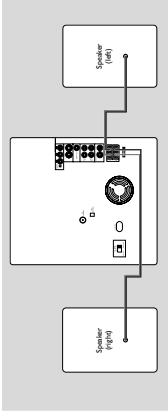

Connect the speaker wires to the SPEAKERS (FRONT) terminals, right speaker to "R" and left speaker to "L"; coloured (marked) wire to "+", and black (unmarked) wire to "-"; Fully insert the stripped portion of the speaker wire into the terminal as shown.

Speakers	⊖	⊕
Front Left (L)	Black	White
Front Right (R)	Black	Red

Notes:

- For optimal sound performance, use the supplied speakers.
- Do not connect more than one speaker to any one pair of +/- speaker terminals.
- Do not connect speakers with an impedance lower than the speakers supplied. Please refer to the SPECIFICATIONS section of this manual.

IMPORTANT!

The type plate is located on the rear of the system.

To avoid overheating of the system, a safety circuit has been built in.

Therefore, your system may switch to Standby mode automatically under extreme conditions. If this happens, let the system cool down before reusing it.

Preparations

Step 5: Setting language preference

You can select your preferred language settings so that this DVD Mini Hi-Fi System will automatically switch to the language for you whenever you load a disc. If the language selected is not available on the disc, the language set by default will be used instead. But the menu language of the DVD Mini Hi-Fi System cannot be changed once selected.

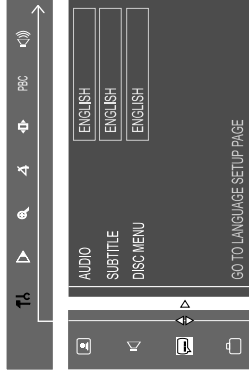

1 In disc mode, stop playback and press **SYSTEM MENU**.

2 Select **FA** icon and press **▼**.

3 Press **◀◀ / ▶▶ / ▲ / ▼** keys on the remote control to select your preferred option.

→ Move to **FA** and press **▶▶**.

→ Move to one of the following and press **▶▶**.

- Audio (disc's soundtrack)
- Subtitle (disc's subtitles)
- Disc Menu (on screen menu)

4 Press **▲ / ▼** to select a language and press **OK**.

5 Repeat steps 3~4 for other settings.

To remove the menu

Press **SYSTEM MENU**.

Step 4: Setting speakers

IMPORTANT!

- This function is only available when you have connected other 3.1-channel speakers.

You can adjust the delay time (center and rear only) for individual speakers to optimize the sound effect according to your surroundings and setup. Speaker settings are only active on effective in the case of Multi-channel audio output.

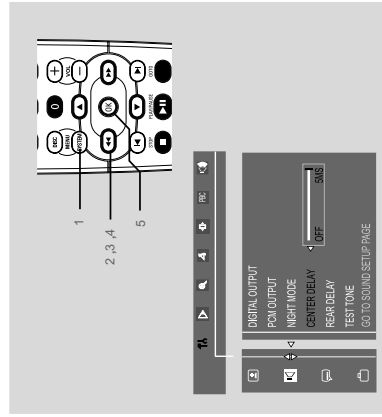

1 In disc mode, press **SYSTEM MENU**.

2 Select **FA** icon and press **▼**.

3 Press **◀◀ / ▶▶ / ▲ / ▼** keys on the remote control to select your preferred option.

→ Move to **FA** and press **▶▶**.

→ Move to "CENTER DELAY" or "REAR DELAY" and press **▶▶**.

4 Press **▶▶** to set CENTER DELAY or REAR DELAY values you want.

→ Use longer delay time if the surround speakers are closer to the listener than the front speakers.

5 Press **OK** to confirm.

To remove the menu

Press **SYSTEM MENU**.

PREPARATIONS AND CONTROLS

Connections

Step 3: Connecting TV set

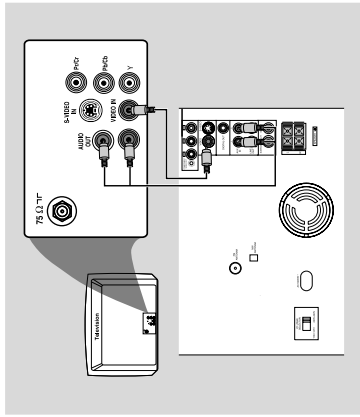

IMPORTANT!

- You only need to make **one video connection** from the following options, according to the capabilities of your TV system.
 - **S-Video or Component Video connection provides higher picture quality. These options must be available on your TV set.**
 - **Connect the system directly to the TV set.**

Using Video In jack (CVBS)

Use the composite video cable (yellow) to connect the system's **VIDEO** jack to the video input jack (or labeled as A/V In, Video In, Composite or Baseband) on the TV set. To listen to TV channels through this system, use the audio cables (white/red) to connect **AUX IN (L/R)** jacks to the corresponding AUDIO OUT jacks on the TV set.

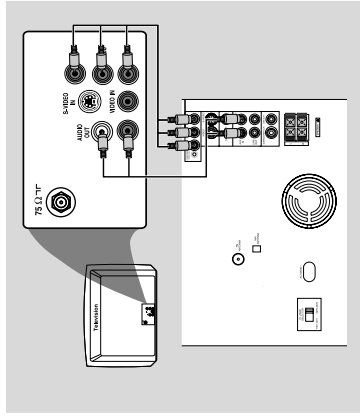

Using component Video In jack (Pr/Pb/Y)

Use the component video cables (red/blue/green) to connect the system's **Pr/Pb/Y** jacks to the corresponding Component video input jacks (or labeled as Pr/Cr-Pb/Cb/Y or YUV) on the TV set. To listen to TV channels through this system, use the audio cables (white/red) to connect **AUX IN** jacks to the corresponding AUDIO OUT jacks on the TV set.

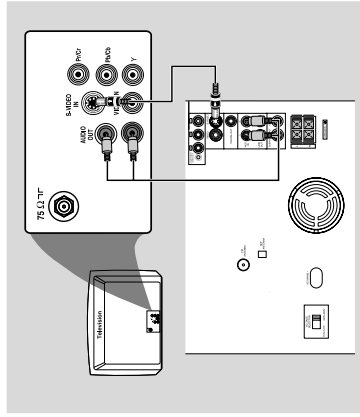

Using S-Video In jack

Use the S-Video cable (not supplied) to connect the system's **S-VIDEO OUT** jack to the S-Video input jack (or labeled as Y/C or S-VHS) on the TV set. To listen to TV channels through this system, use the audio cables (white/red) to connect **AUX IN** jacks to the corresponding AUDIO OUT jacks on the TV set.

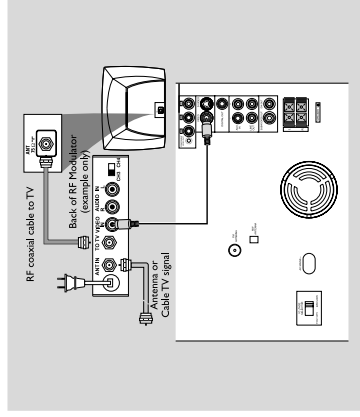

IMPORTANT!

- If your TV set only has a single **Antenna In jack (or labeled as 75 ohm or RF In)**, you will need a **RF modulator in order to view the DVD playback via TV. See your electronics retailer or contact Philips for details on RF modulator availability and operations.**

Using an accessory RF modulator

Use the composite cable (yellow) to connect the system's **VIDEO** jack to the video input jack on the RF modulator. Use the RF coaxial cable (not supplied) to connect the RF modulator to your TV's RF jack.

PREPARATIONS AND CONTROLS

Connections

Step 4: Connecting FM/MW antennas

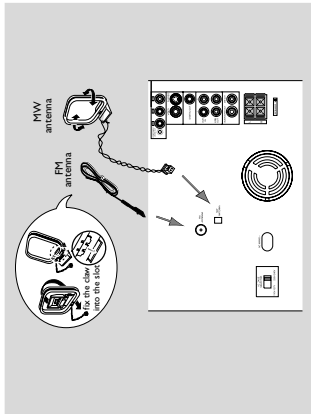

Connect the supplied MW loop antenna to the **MW** jack. Place the MW loop antenna on a shelf or attach it to a stand or wall.

Connect the supplied FM antenna to the **FM** jack. Extend the FM antenna and fix its end to the wall.

For better FM stereo reception, connect an outdoor FM antenna to the FM ANTENNA terminal.

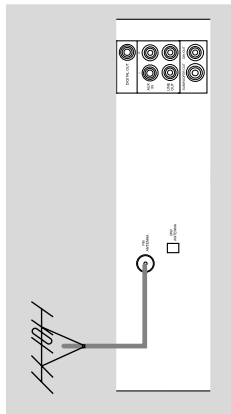

Notes:

- Adjust the position of the antennas for optimal reception.
- Position the antennas as far as possible from your TV set, VCR or other radiation sources to prevent unwanted interference.

Step 5: Connecting the power cord

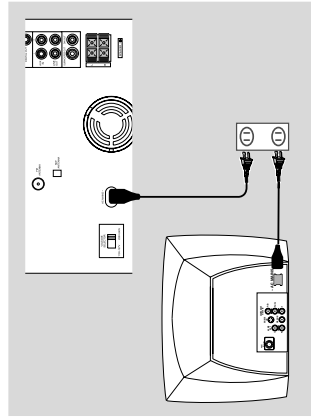

After everything is connected properly, plug in the AC power cord to the power outlet.

Never make or change any connection with the power switched on.

On the DVD Mini Hi-Fi System

"AUTO INSTALL - PRESS PLAY" may appear on the display panel. Press **▶▶▶** on the front panel to search and store all available radio stations or press **■** to exit. (See page 37, Tuner Operations - Presetting radio stations).

If your system is equipped with a Voltage Selector, set the VOLTAGE SELECTOR to the local power line voltage.

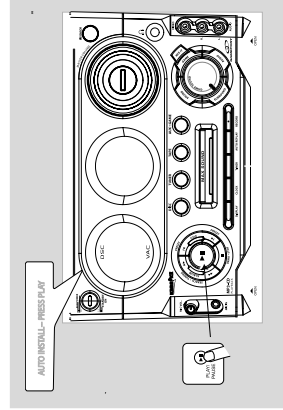
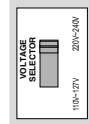

Connections

Step 6: Connecting a VCR or cable/satellite box

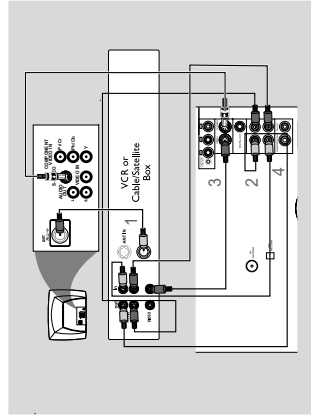

Viewing and listening to playback

1 Connect the VCR or Cable/Satellite Box to the TV system as shown.

2 Connect the system's AUX IN jacks to the AUDIO OUT jacks on the VCR or Cable/Satellite box.

Before starting operation, press **AUX/GAME** on the remote control to select "AUX" in order to activate the input source.

Using the VCR for recording DVDs

Some DVDs are copy-protected. You cannot record or dub protected discs using a VCR.

3 Connect the system's **VIDEO** jack to the VIDEO IN jack on the VCR.

4 Connect the system's **LINE OUT (R/L)** jacks to the AUDIO IN jacks on the VCR. This will allow you to make analog stereo (two channel, right and left) recording.

To view DVD playback while recording

You must connect the system to your TV system using the S-VIDEO (as shown above) or the Component (Pr-Pb-Y) video connection.

Step 7: Connecting digital audio equipment

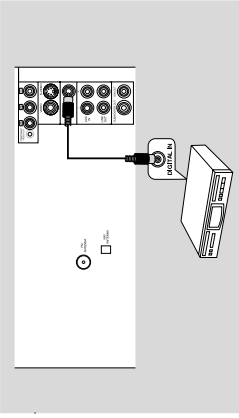

Recording (digital)

Connect the system's DIGITAL OUT jack to the DIGITAL IN jack on a digital recording device (DTS-Digital Theater System compatible, with a Dolby Digital decoder, for example).

Before operation, set the DIGITAL OUTPUT according to the audio connection. (See Using the Setup Menu - Setting the digital output).

Step 8: Connecting to game console

IMPORTANT!

- **Gameport inputs are for the game console only.**

Use the game console's video cable (not supplied) to connect its video output to the GAMEPORT-VIDEO terminal.

Use the game console's audio cable (not supplied) to connect its audio output to the GAMEPORT-AUDIO L/ AUDIO R terminals. Use the video cable (yellow) to connect the VIDEO OUT terminal to the video input on the TV for viewing.

Notes:

- On the TV, the Video Input jack is usually yellow and might be labeled A/V In, CVBS, composite or Baseband.
- To avoid magnetic interference, do not position the front speakers too close to your TV.

FUNCTIONAL OVERVIEW

Functional Overview

- Controls on the system**
- ① **ECO POWER/ STANDBY ON**
 - to switch the system on, to Eco Power or Standby mode.
 - ② **DISPLAY SCREEN**
 - to view the current status of the system.
 - ③ **SOURCE**
 - to select the following:
 - DISC (DISC 1•2•3)**
 - to select disc tray 1, 2 or 3
 - TUNER (BAND)**
 - to select waveband: FM or MW.
 - TAPE (TAPE 1-2)**
 - to select tape deck 1 or 2.
 - AUX•GAME**
 - to select a connected external source: TV/CDR, AUX (auxiliary) or Gameport mode.
 - ④ **PREV / PRESET / NEXT ◀▶**
 - for DISCto select previous/next title, chapter or track during playback
 - for TUNERto select a preset radio station.
 - for CLOCKto set the hour.
 - ⑤ **SEARCH•TUNING ◀◀ / ▶▶ (ALBUM - / +)**
 - for DISCto search backward/forward, to select previous/next album in MP3/WMA stop mode (with MENU ON);
 - for TAPEto rewind or fast forward.
 - for TUNERto tune to a lower or higher radio frequency.
 - for CLOCKto set the minute.
 - ⑥ **MIC VOL./ MIC IN**
 - to adjust the mixing level for karaoke or microphone recording.
 - to connect microphone jack.
 - ⑦ **▶ II (PLAY/PAUSE)**
 - for DISCto start or interrupt playback.
 - for TAPEto start playback.
 - for PLUG&PLAY ... (on the system only) to initiate plug & play mode.

Functional Overview

- ⑧ **DEMO•STOP ■**
 - for DISCto stop playback or to clear a programme.
 - for DEMO (in Standby or ECO power mode) to activate/deactivate demonstration.
 - for PLUG&PLAY ... (on the system only) to exit plug&play mode.
- ⑨ **MAX SOUND**
 - to activate or deactivate MAX sound.
- ⑩ **DISPLAY**
 - to display disc information during disc playback.
- ⑪ **CLOCK**
 - to view or to set clock.
- ⑫ **TIMER**
 - to view or to set timer.
- ⑬ **TAPE DECK 1 / 2**
- ⑭ **▲ OPEN**
 - to open the tape deck door.
- ⑮ **AUTO REPLAY**
 - to select continuous playback in either AUTO PLAY or ONCE mode only.
- ⑯ **RECORD**
 - to start recording on tape deck 2.
- ⑰ **VIDEO**
 - use a video cable to connect to your game console's video output
- AUDIO L./ AUDIO R.**
 - use an audio cable to connect to your game console's left/right audio output.
- ⑱ **SOUND**
 - to select various sound effect.
- SURROUND**
 - to select various surround sound effect.
- AUDIO**
 - to select the preferred language for audio
 - to select AUDIO channel in karaoke mode.
- MIX IT**
 - to mix the game sound with your favorite music from one of the music sources (DISC, TUNER, TAPE1/2, or AUX)
- GAME**
 - to select different type of equaliser setting for Gameport (SPEED, PUNCH or BLAST).
- GAME SOUND**
 - to adjust the game's output volume level.

Remote control

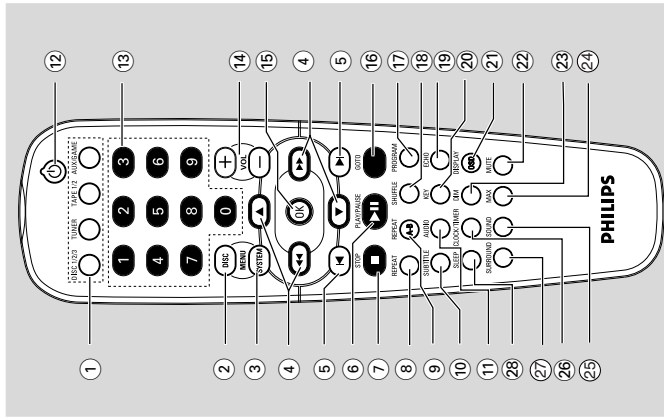

Notes:

- First, select the source you wish to control by pressing one of the source select keys on the remote control (DISC or TUNER, for example).
- Then select the desired function (▶▶, ▶◀ or ▶/ for example).
- ① **SOURCE**
 - to select the relevant active mode: DISC1/2/3, TUNER, TAPE1/2, or AUX/GAME.
 - TUNER: toggles between FM and MW band.
 - AUX/GAME: toggles between AUX and GAMEPORT mode.
- ② **DISC MENU (disc mode only)**
 - to enter or exit the disc contents menu.
- ③ **SYSTEM MENU (disc mode only)**
 - to enter or exit the system menu bar.
- ④ **◀◀ / ▶▶ / ▲ / ▼**
 - to select movement direction in disc contents menu/system menu bar.
 - to tuner mode, to tune to lower or higher radio frequency. (◀◀ / ▶▶)

FUNCTIONAL OVERVIEW

Functional Overview

- in Disc mode, press to fast reverse/forward the disc.
- ⑤ **◀/▶**
 - in Disc mode, press to skip to the previous/next chapter/track.
 - in Tuner mode, to select a preset radio station number
- ⑥ **PLAY/PAUSE ▶||**
 - to start or interrupt disc playback.
 - to resume playback from last stop point.
- ⑦ **STOP ■**
 - to stop playing the disc.
- ⑧ **REPEAT**
 - to select variations of continuous playback.
- ⑨ **REPEAT A-B**
 - to repeat a specific section on a disc.
- ⑩ **SUBTITLE**
 - to select desired subtitle.
- ⑪ **AUDIO**
 - to select the audio channel.
- ⑫ **POWER ⏻**
 - to switch to eco power or standby mode.
- ⑬ **Numeric Keypad (0-9)**
 - to enter a track/title number of the disc.
 - to enter a number of preset radio stations.
- ⑭ **VOL +/-**
 - adjust the volume level.
 - adjust key control/ ECHO level in karaoke mode.
 - adjust speakers level in speaker setting mode.
- ⑮ **OK**
 - to exit or confirm the selection.
- ⑯ **GOTO**
 - to go direct to desired title, chapter or time.
- ⑰ **PROGRAM**
 - in disc mode, to program favorite tracks.
 - in tuner mode, to program favorite stations.
- ⑱ **SHUFFLE**
 - to playback in random mode.
- ⑲ **ECHO**
 - to adjust the echo level in karaoke mode.
- ⑳ **KEY**
 - to change the tone level to suit your vocal range.
- ㉑ **DISPLAY (OSD)**
 - to view the time, title or chapter information.
- ㉒ **MUTE**
 - to interrupt or resume sound reproduction.
- ㉓ **DIM**
 - to select different brightness for VFD.
- ㉔ **MAX**
 - to activate or deactivate MAX sound.
- ㉕ **SOUND**
 - to select various sound effect.
- ㉖ **CLOCK/TIMER**
 - to view clock/ timer.
 - to enter timer setting mode.
- ㉗ **SURROUND**
 - to select various surround sound effect.
- ㉘ **SLEEP**
 - to set the sleep (auto-off) timer function.

TROUBLESHOOTING

Troubleshooting

WARNING

Under no circumstances should you try to repair the system yourself, as this will invalidate the warranty. Do not open the system as there is a risk of electric shock.

If a fault occurs, first check the points listed below before taking the system for repair. If you are unable to remedy a problem by following these hints, consult your dealer or Philips for help.

Problem	Solution
No power.	<ul style="list-style-type: none"> ✓ Check if the AC power cord is properly connected. ✓ Check if the disc is inserted upside down. ✓ Wait until the moisture condensed at the lens has cleared. ✓ Replace or clean the disc, see "Maintenance". ✓ Use a readable disc or correctly recorded format MP3-CD.
No picture.	<ul style="list-style-type: none"> ✓ Select the appropriate video input mode on the TV set. ✓ Check if the TV set is switched on. ✓ Check the video connection. ✓ Check if the system is securely connected. ✓ Sometimes a slight picture distortion may appear. This is not a malfunction. ✓ Clean the disc. ✓ Connect the system to the S-video input of your TV set.
Distorted or poor picture.	<ul style="list-style-type: none"> ✓ The aspect ratio is fixed on the DVD disc. ✓ The aspect ratio may not be changed for some TV systems. ✓ Insert a readable disc. ✓ Check the disc type, color system and region code. ✓ Clean the disc. ✓ Place the disc with the playback side down. ✓ Press SYSTEM MENU to turn off the setup menu. ✓ Cancel the parental control rating function or change the rating level. ✓ Moisture has condensed inside the system. ✓ Remove the disc and leave the system turned on for about an hour. ✓ Disconnect the power plug from the jack and insert again.
The aspect ratio of the screen cannot be changed even though you have set the TV shape.	
The DVD player does not start playback.	
The system does not respond when the buttons are pressed.	

Problem	Solution
The language for the sound or subtitle cannot be changed when playing a DVD.	<ul style="list-style-type: none"> ✓ Multi-language sound or subtitle is not recorded on the DVD. ✓ Changing the language for the sound or subtitle is prohibited on the DVD. ✓ Make sure the component is connected correctly. ✓ Press the correct function button for the input source. ✓ Adjust the volume. ✓ Disconnect the headphones. ✓ Check that the speakers are connected correctly. ✓ Check if the stripped speaker wire is clamped. ✓ If the system is in pause, slow motion or fast forward/reverse mode, press ▶ to resume the normal play mode. ✓ Make sure the MP3-CD was recorded within 32-256 kbps bit rate with sampling frequencies at 48 kHz, 44.1 kHz or 32 kHz. ✓ If the signal is too weak, adjust the antenna or connect an external antenna for better reception. ✓ Increase the distance between the System and your TV set or VCR. ✓ Clean deck parts, see "Maintenance". ✓ Use only NORMAL tape. ✓ Apply a piece of adhesive tape over the missing tab space. ✓ Remove and reconnect the AC power plug and switch on the system again.
No image is output when a function is selected.	
Sound cannot be heard or is of poor quality	
Poor radio reception.	
Recording or playback cannot be made	
The tape deck door cannot open	
Left and right sound outputs are reversed.	
The remote control does not function.	
The display is dark	
The timer is not working	
The Clock/Timer setting is erased	

System, Region code, Tuner, etc. setting procedure

1) System Reset

- Press "SYSTEM" button on R/C. TV show "SETUP"
- Select the menu using the "▼" and "▶" button on R/C
- Go feature setup page to do system reset

2) Region Code Change

After replacement / repair of the MPEG board, the customer setting and the region code may be lost. Changing the Region code will put the player back in the state which it has left the factory.

Region Code

1	USA
2	EU
3	AP
4	Australia, NZ, Latam
5	RUSSIA, INDIA
6	CHINA

TV System

1	NTSC
2	PAL
3	AUTO

Menu/ Audio Subtitle (AS) Language

1	English
2	English
3	English
4	English

AFS

001	LX3000D/LX3500D /MRD200
002	MX3600D/MX3800
003	LX3700D/LX3750W
005	MRD210
006	MX3660D
008	FW-D550/FWD570

oem derivative

08

- region code = 1 digit
- tv system = 1 digit
- "as/menu lang" = 1 digit
- "AFS" = "architecture Feature Set" = 3 digits

This field is used to define the architecture / features sets for each product.

- "oem derivative" = 2 digit

This field is used to define the OEM set. This will affect the background display.

Hence in total, reprogramming will be done by way of the remote control. It should run as below :-

- Put the player in stop mode. No disc loaded.
- Press the following key on remote control:

For FW-D550 /21M (A/P) :

<PLAY> <159> <331> <008> <08> <PLAY>

* After the Region Code is changed it is necessary to reset the system so that the new Region Code will be fully effective. All customer setting will be lost.

* On top of the maximum number of times allowed for changing the region code is changed to 25.

* When the counter reaches 25, you will not be able to further change the code until you reset the timer by the Region Code timer reset procedure

CAUTION !

This information is confidential and may not be distributed. Only a qualified service person should reprogram the Region Code.

3) Region code change timer reset

Press below key to reset the timer :

- In DISC source, stop mode and no disc in tray.
- Press R/C "Play -159-PLAY" to reset timer to 25

4) Tuner area change

- Press the "OPEN/CLOSE" button to open the set's door
- Press "1" "5" "9" button by using R/C.
- TV Show "TUNER AREA"
- Select the tuner area you want by using the "▼" and "▶" button on R/C, then press "OK" to confirm. TV show "TUNER AREA CHANGED"

If you didn't press it in five seconds, the system will remain original status.

AREA	BAND	FREQUENCY (Hz)	STEP(Hz)
A/P (21M)	FM	87.5M	108M
	MW	531K	1602K
		530K	1710K

Note :-

Please refer to the above different tuner area.

5. Video Out Change

- Press "SYSTEM" on R/C button
- Select the menu using the "▼" and "▶" button on R/C
- Go picture setup page select Video out item.

6. Password Change

- Press "SYSTEM" on R/C button
 - Select the menu using the "▼" and "▶" button on R/C
 - Go feature setup page select "PASSWORD". TV show "ENTER CODE". Press 4 times of "STOP" button on R/C.
 - Select "PARENTAL" "8 ADULT" on TV.
 - Enter PASSWORD to "1234".
- * "1234" is a default password supplied.

7. Checking on the Software version

- Open the CD door.
- Press "123" and "OK" on the remote control.
- TV will show the version on screen.

8. Upgrading new software

- Open the door, then insert the CD-R program disc.
- Close the door.
- TV will show:-
 - "disc loading"
 - "bank30.rom"
 - "writing" about 6 seconds.
 - "Done"

* The latest upgraded is in version VER*****.

REPAIR INSTRUCTIONS

MAIN UNIT REPAIR CHART

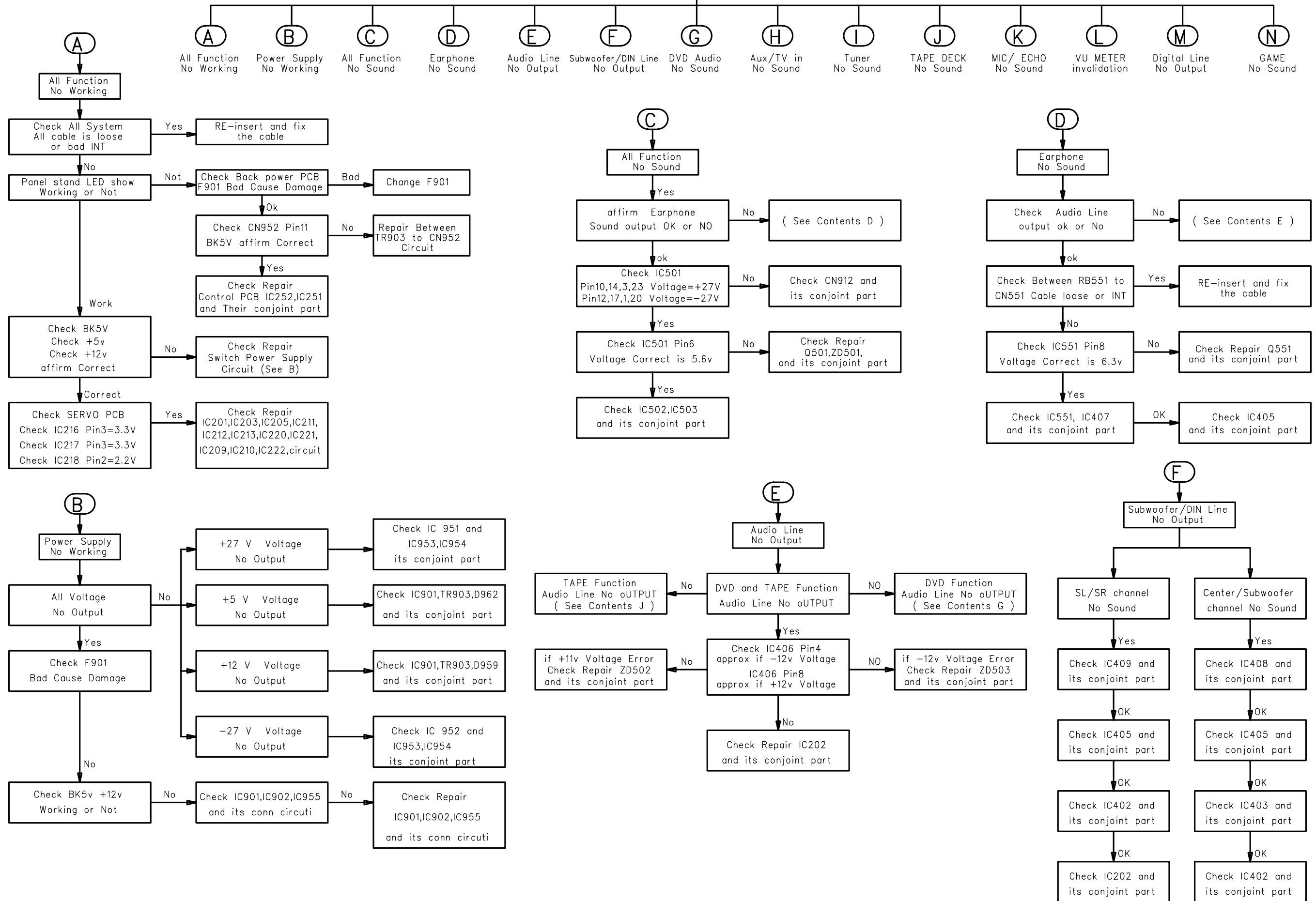

REPAIR INSTRUCTIONS

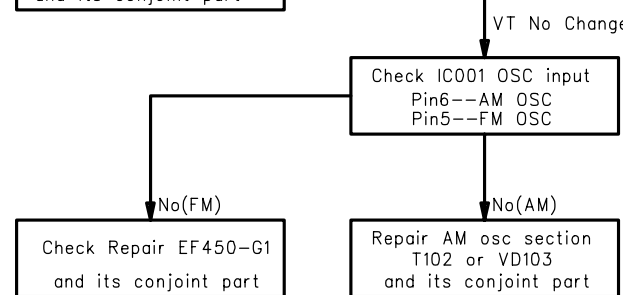
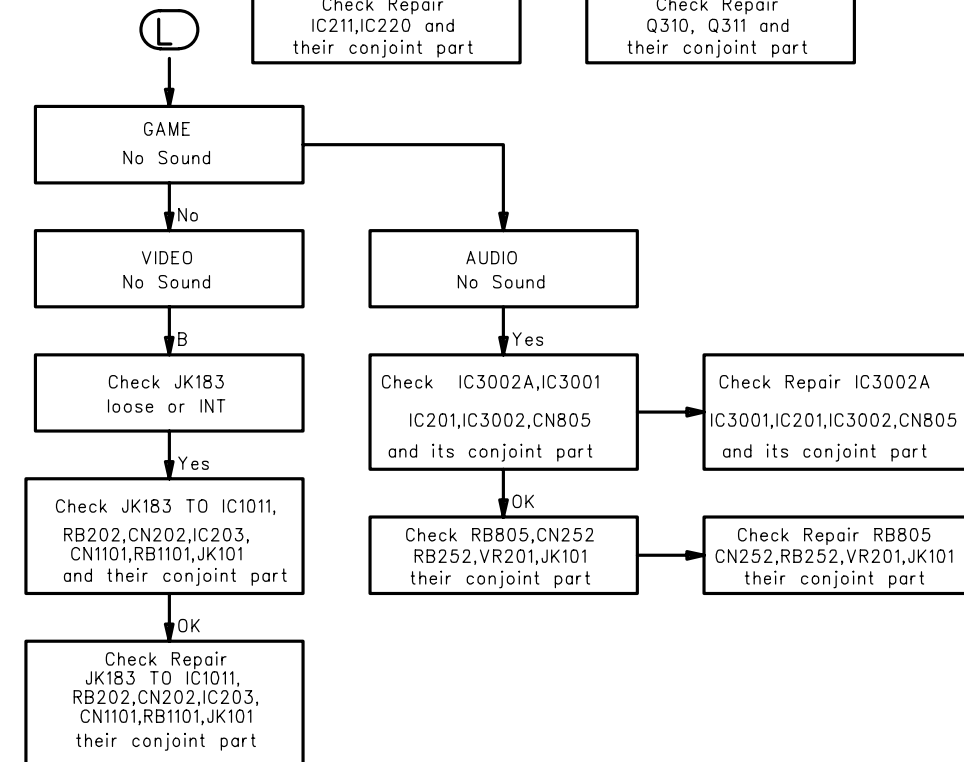
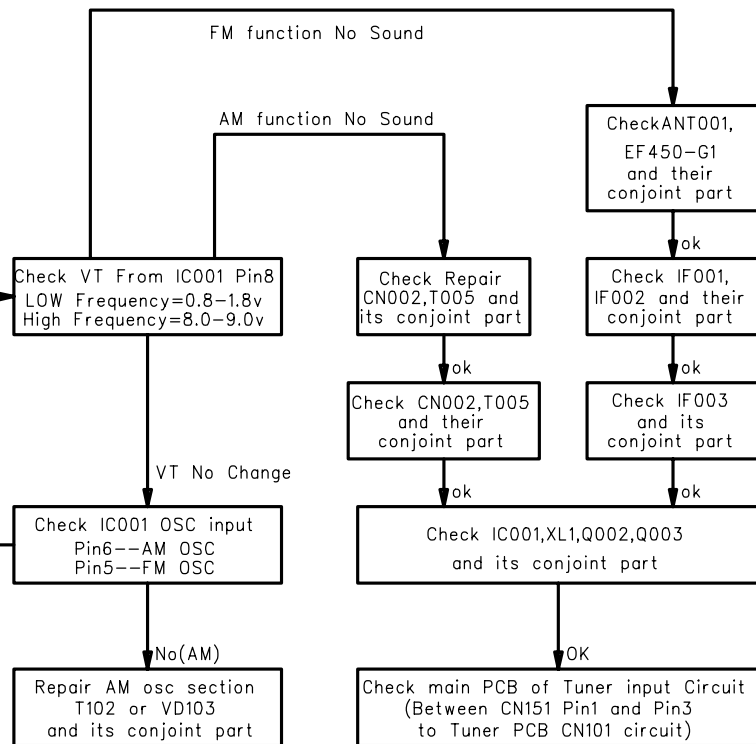
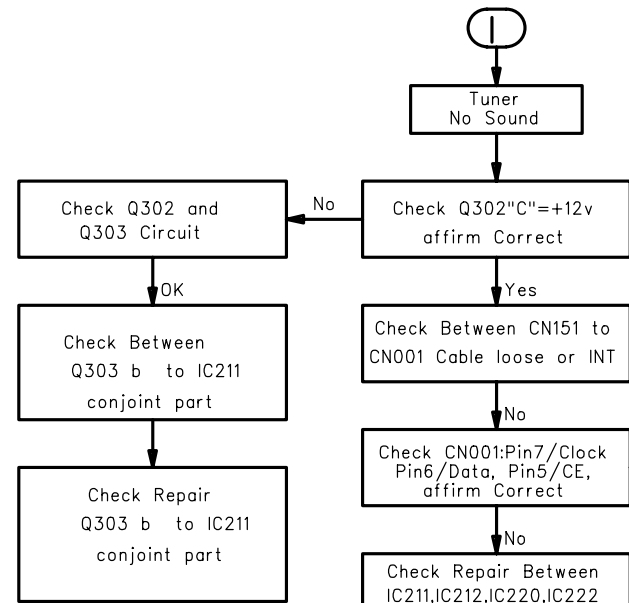
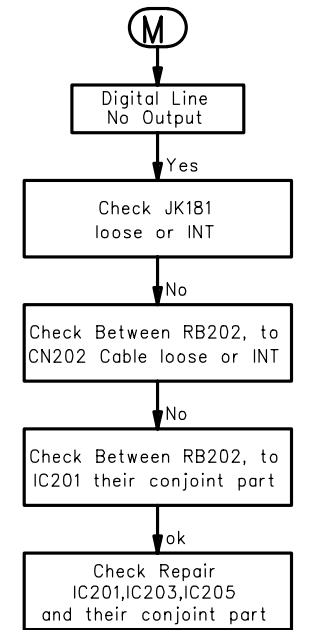
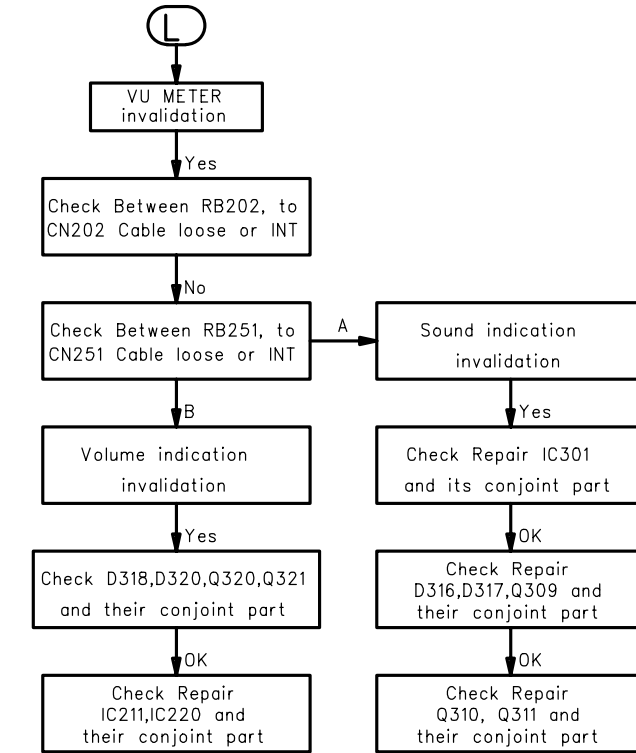
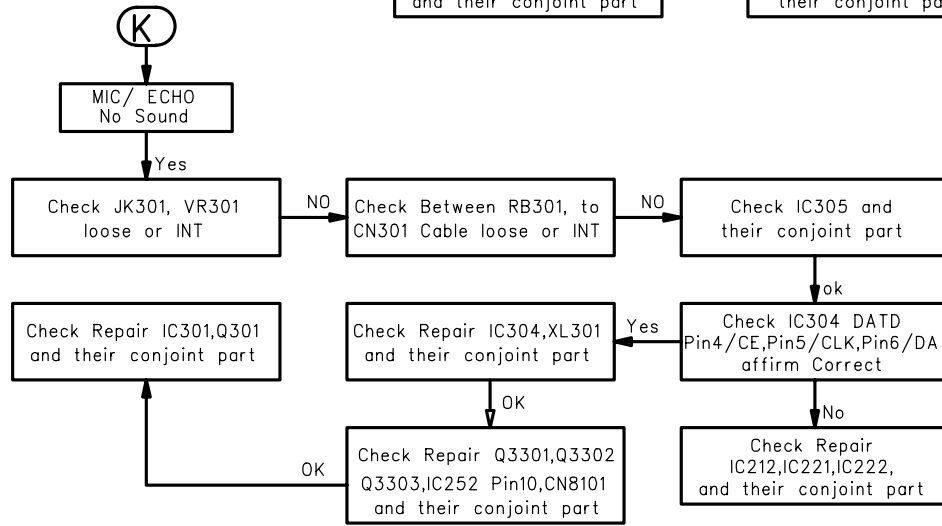
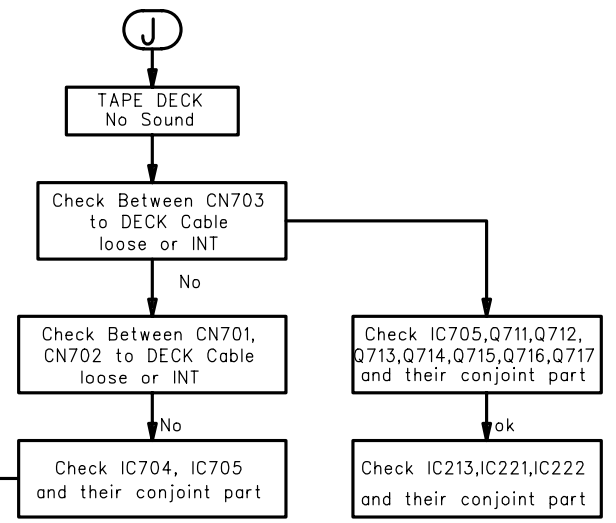
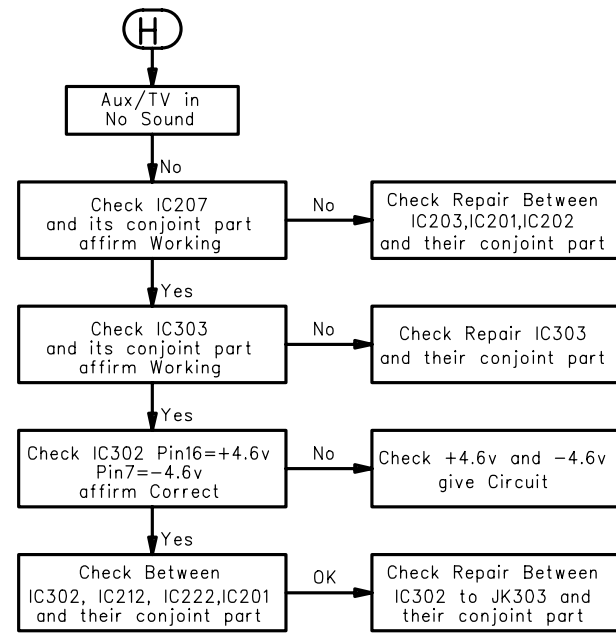
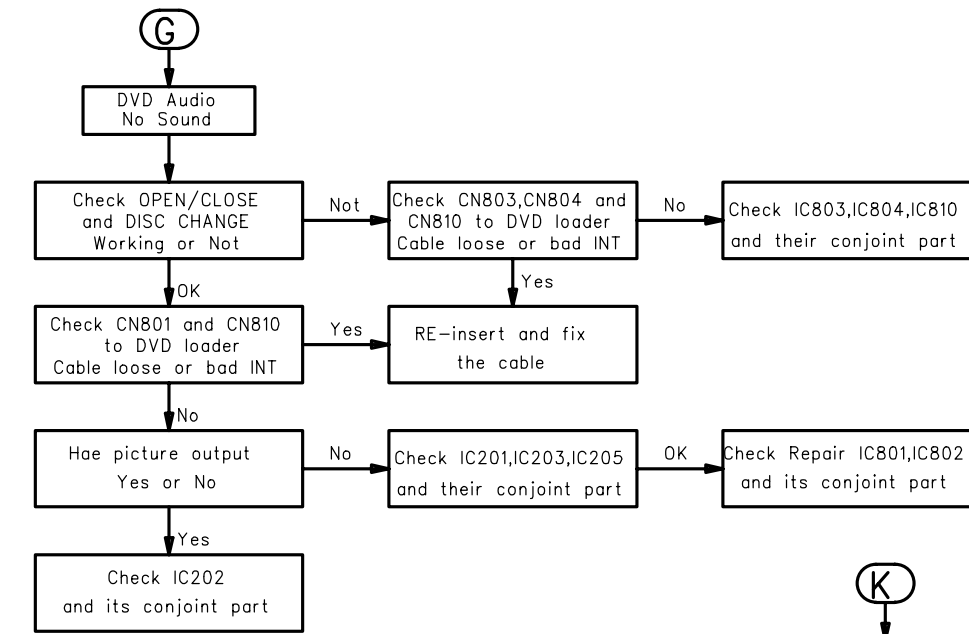

DISMANTLING INSTRUCTIONS

Dismantling of the Cassette Cover

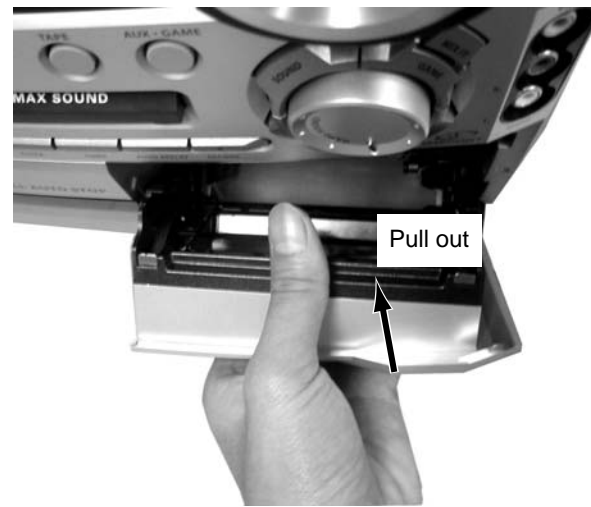

Figure 1

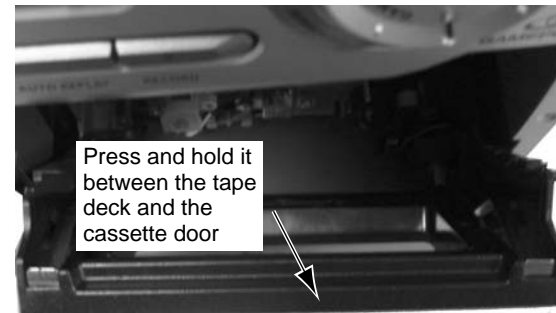

Figure 2

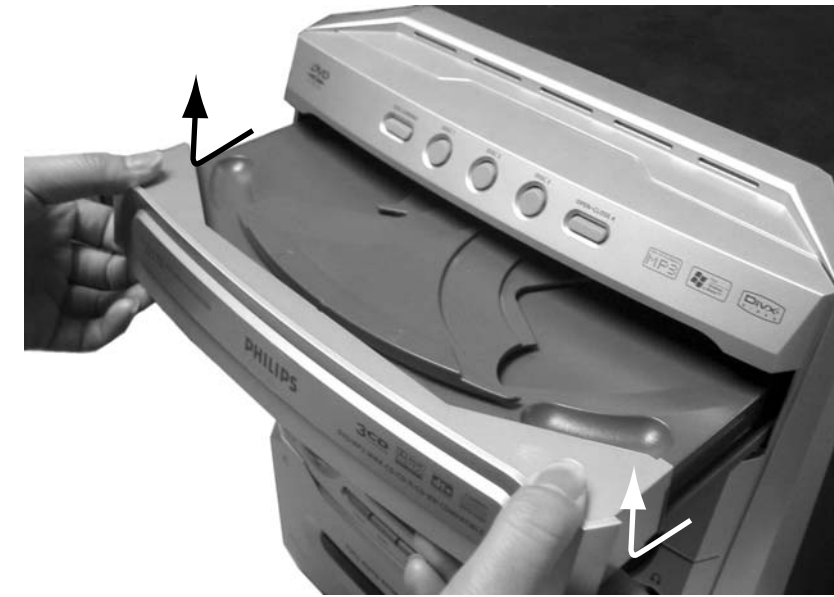

Figure 4

Dismantling the 3CDC Module

- 1) Loosen the 4 screws, slide Cover top (pos 255) towards the rear and remove it upwards.
- 2) Push the gear slowly towards the front as shown in figure 3 until the CDC tray starts to move out of the Front Cabinet. The CDC tray is now disengaged and can be pulled out completely.
- 3) Push the gear slowly towards the front as shown in figure 3 until the CDC tray starts to move out of the Front Cabinet. The CDC tray is now disengaged and can be pulled out completely.
- 4) Remove the Cover Tray as shown in figure 4.
- 5) Loosen 4 screws A to remove the CDC Module (pos 1105) as shown in figure 3.

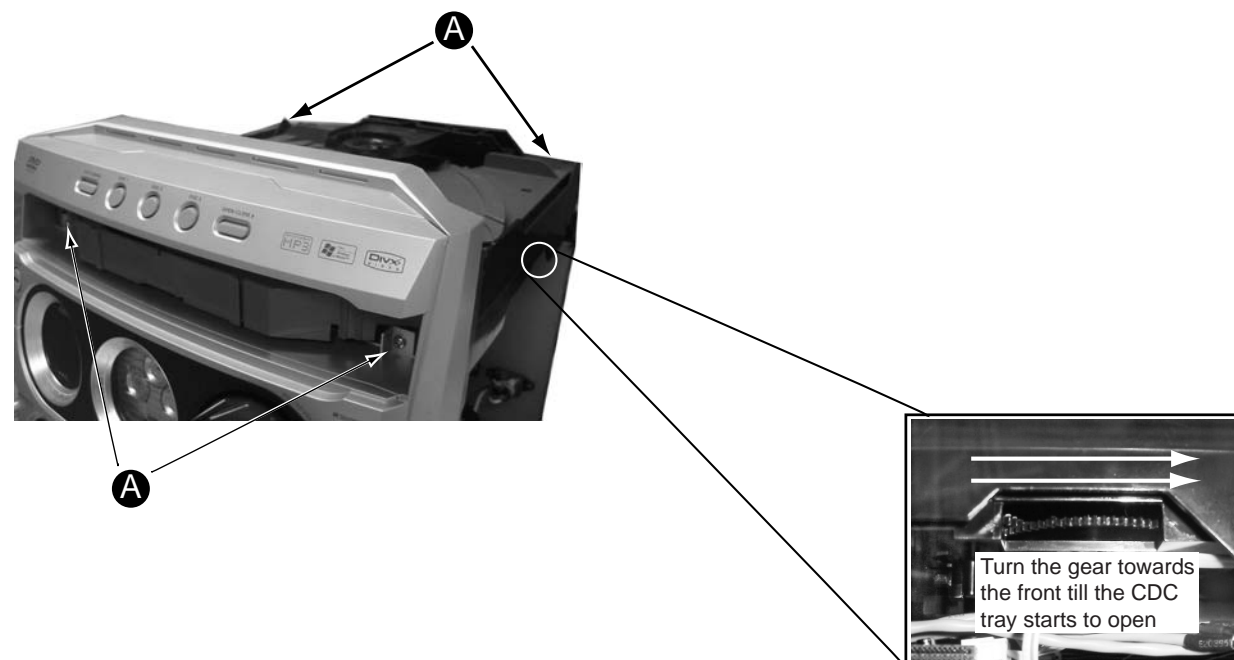

Figure 3

Dismantling of the Cover Front Display and Cover Front Ornamental (pos 130)

- 1) Remove the Volume knobs as stated in Dismantling the Cover Front Display in Figure 5.

Notes: *There is nothing are sandwiched between the Front Cabinet (pos 101) and Cover Front Display (pos 129) but it has to be removed in order to reach the catches for the Cover Front Ornamental (pos 130) .*



Figure 5

Detaching the Main board and Front Cabinet Assembly from the Bottom/Rear assembly

- 1) Release 2 catches 'B' to free the Main board from the Front Cabinet Assembly as shown in figure 6.
- 2) Loosen 2 screws 'D' at the bottom of the Front Cabinet on both sides of the set.
- 3) Release 2 catches 'C' on both sides of the Front Cabinet and pull the Front Cabinet assembly out of the Bottom plate.

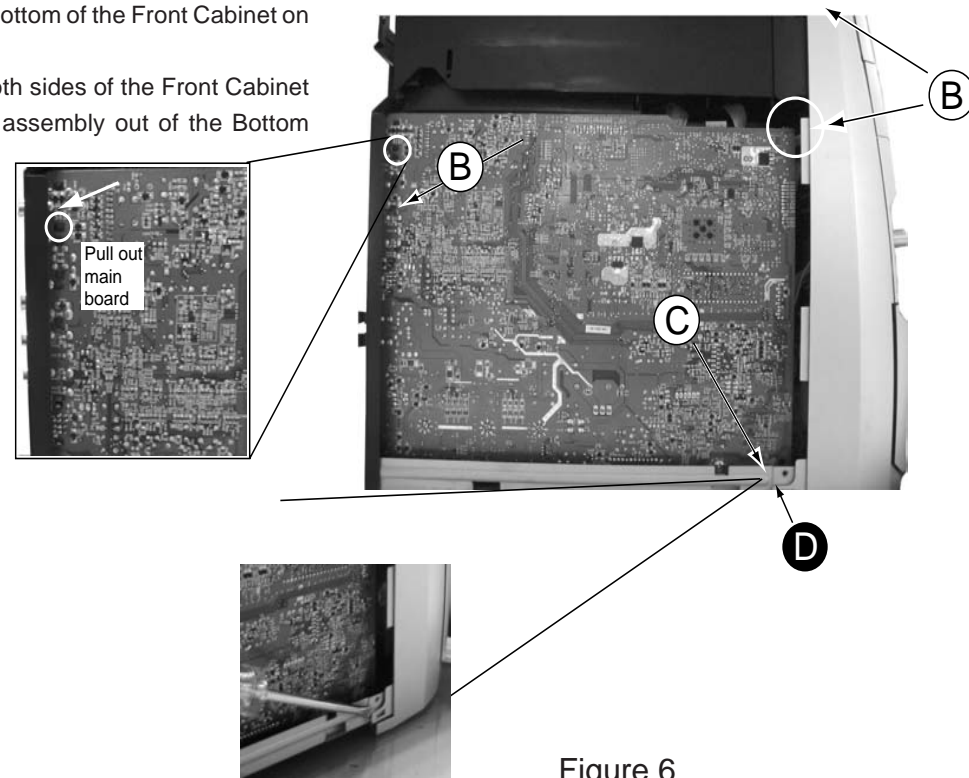

Figure 6

Dismantling of the Key Board , VFD Board, Tape Board and Cassette module

- 1) Loosen 5 screws 'E' to remove the Bracket CDC Right as shown in figure 7.
- 2) Loosen 5 screws 'F' to remove the KEY board figure 7.
- 3) Loosen 9 screws 'H' to remove the VFD Board figure 9.
- 4) Loosen 1 screws 'G' to remove the Tape Board figure 8.
- 5) Loosen 8 screws 'I' to remove the Cassette Module figure 10.

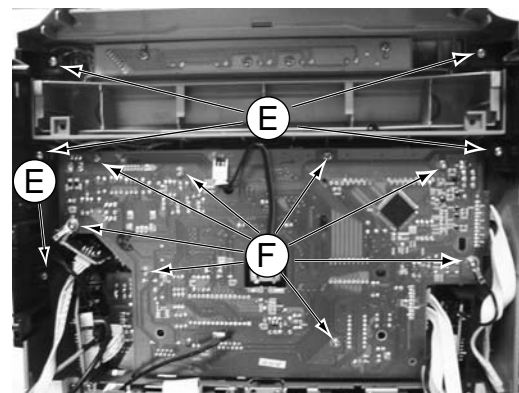

Figure 7

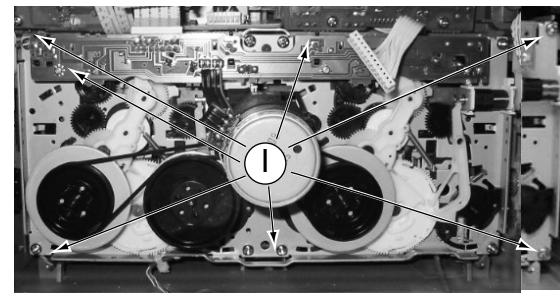

Figure 10

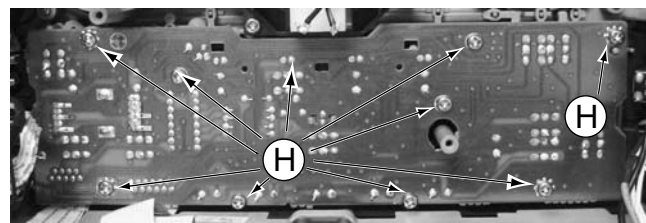

Figure 9

Dismantling of the Rear Panel

- 1) Loosen 8 screws 'J' to remove the Rear Panel figure 11.
- 3) Release 2 catches 'K' on both sides of the Rear Panel with the help of a minus screw driver and pull out the Rear Panel figure 11.

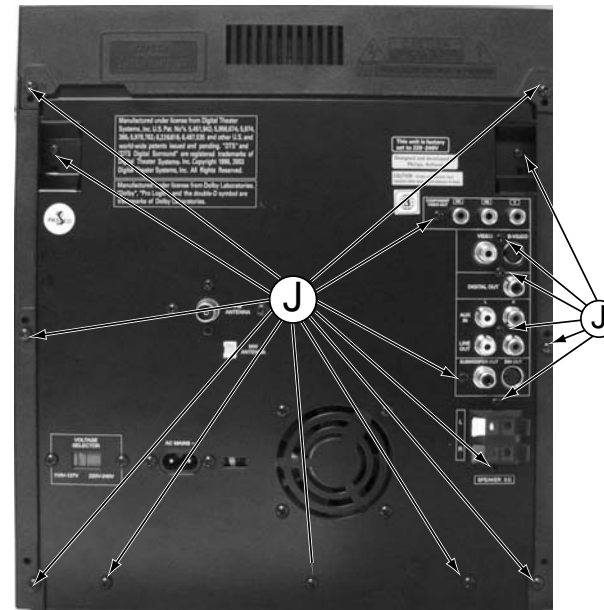

Figure 11

Dismantling of the Power Board

- 1) Loosen 4 screws 'L' to remove the Power Board figure 12.

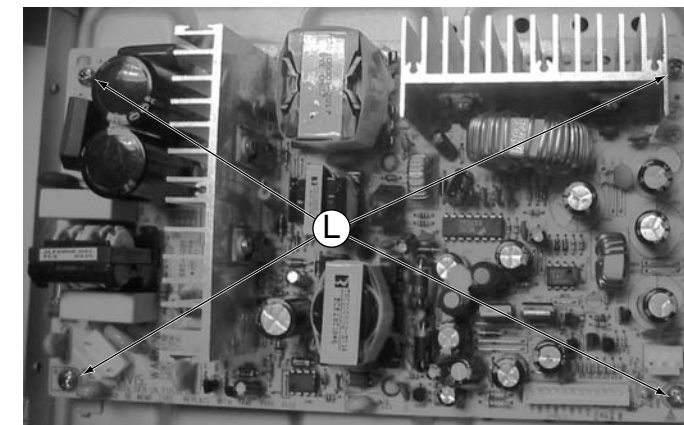
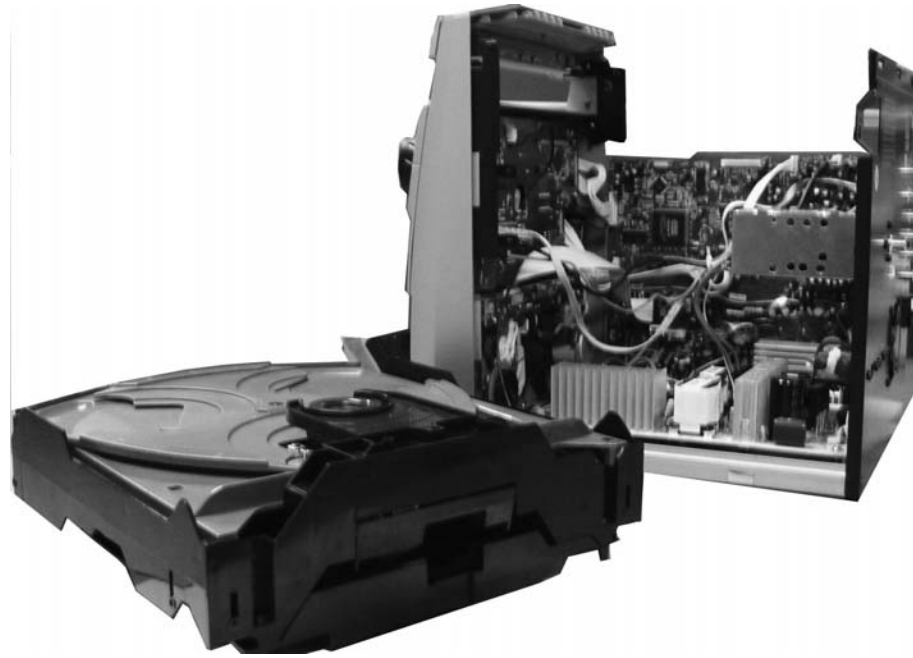

Figure 12

Service positions

Service position A



Service position B

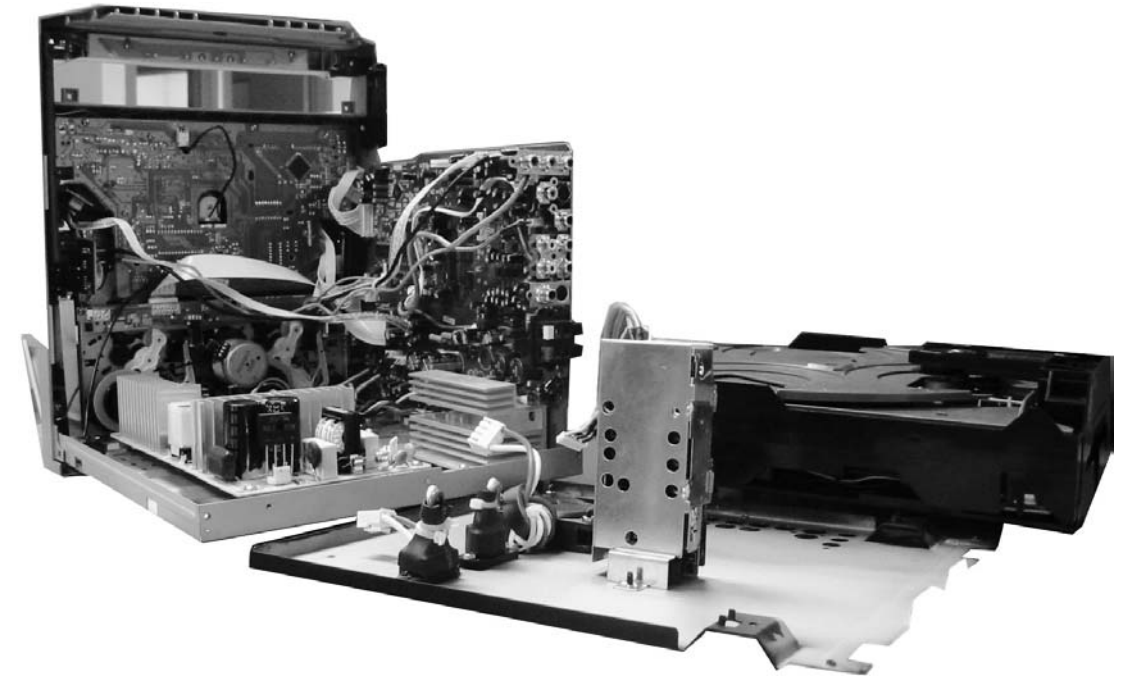

Note: After re-assembly, it is very important to ensure the wires are properly inserted into their respective sockets and routed not to touch or obstruct any moving parts.

Service position C

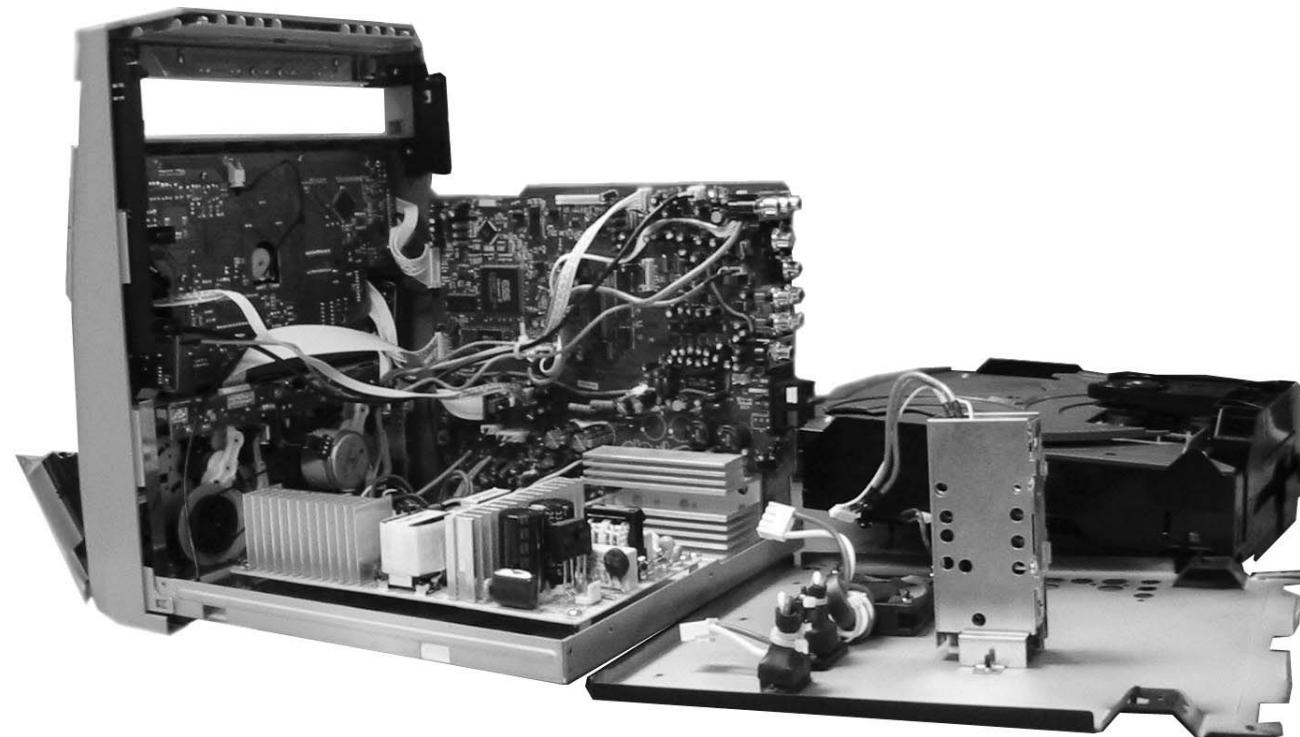

SET BLOCK DIAGRAM

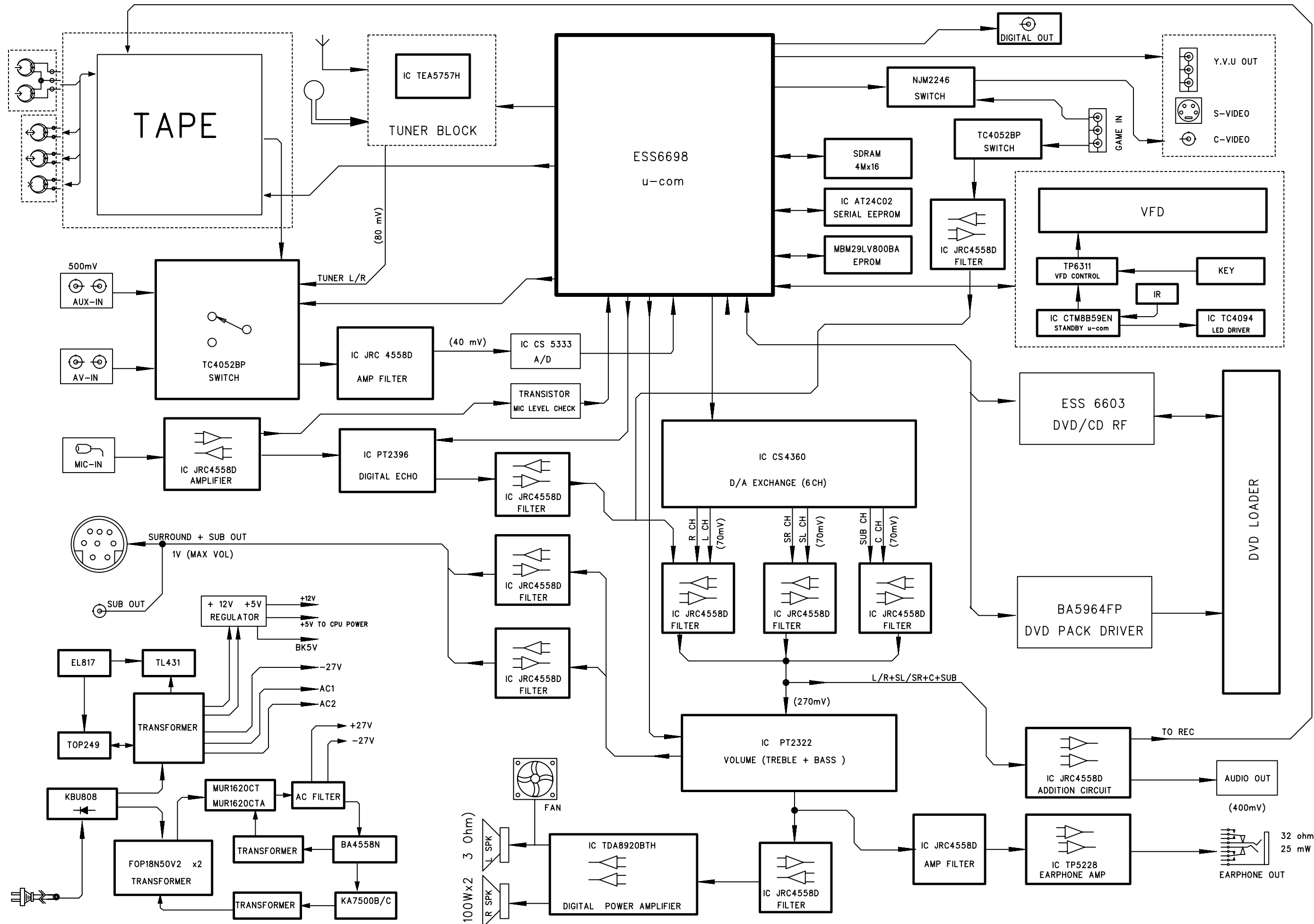

INTERNAL BLOCK DIAGRAM VFD CONTROLLER - IC TP6311QH

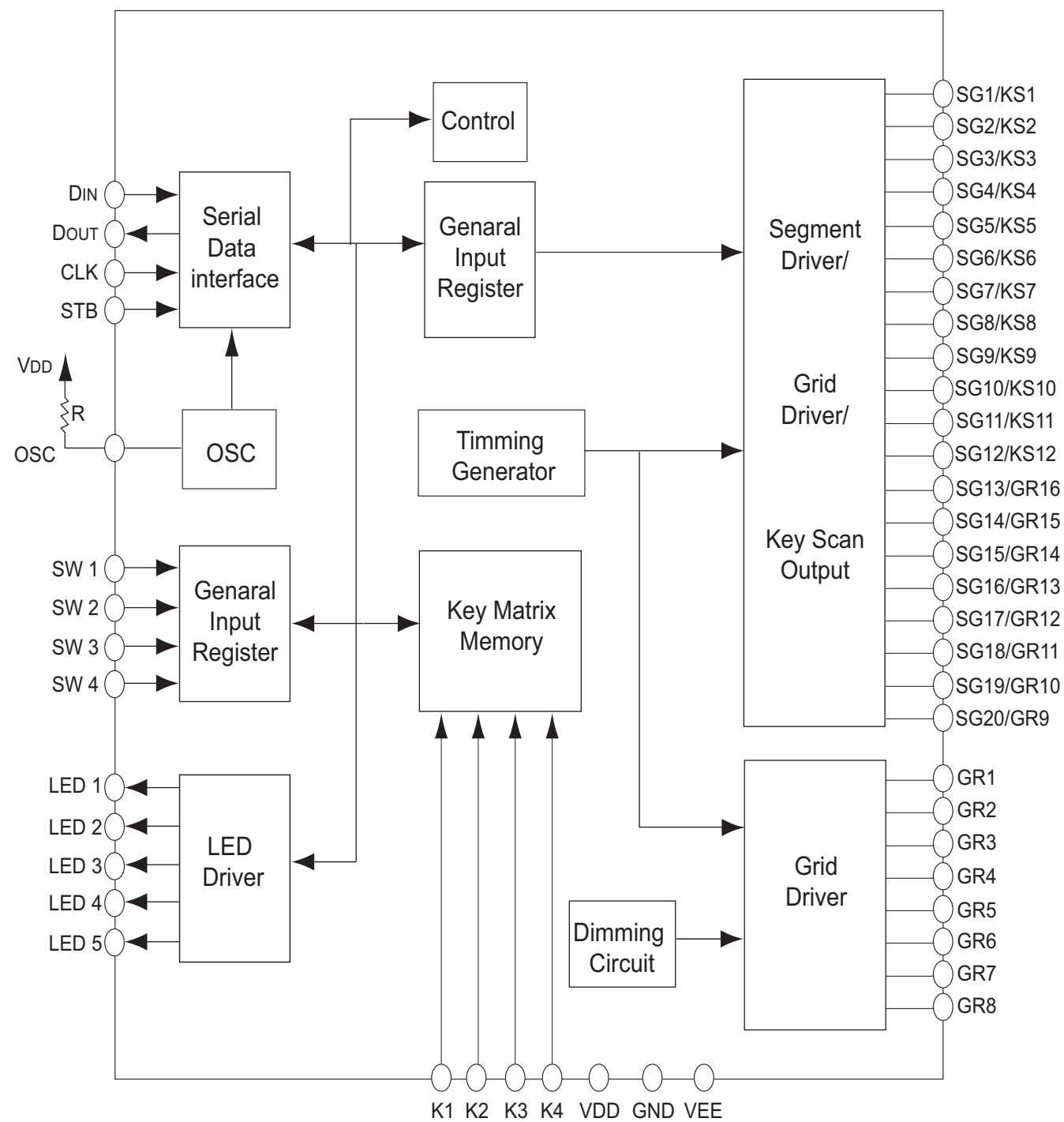

PIN DESCRIPTION VFD CONTROLLER - IC TP6311QH

Pin Name	I/O	Description
SW 1 to SW 4	I	General Purpose Input Pins
DOUT	O	Data Output Pin (N-Channel, Open-Drain) This pin outputs serial data at the falling edge of the shift clock (starting from the lower bit)
DIN	I	Data Input Pin This pin inputs serial data at the rising edge of the shift clock (starting from the lower bit)
NC	-	No Connection
CLK	I	Clock Input Pin This pin reads serial data at the rising edge and outputs data at the falling edge.
STB	I	Serial Interface Strobe Pin The data input after the STB has fallen is processed as a command. When this pin is "HIGH", CLK is ignored.
K 1 to K 4	I	Key Data Input Pins The data inputted to these pins are latched at the end of the display cycle.
VDD	-	Logic Power Supply
SG1/KS1 to SG12/KS12	O	High-Voltage Segment Output Pins Also acts as the Key Source
SG20/GR9 to SG19/GR10 SG18/GR11 to SG13/GR16	O	High Voltage Segment/ Grid Output Pins
VEE	-	Pull-Down Level
GR1 to GR8	O	High-Voltage Grid Output Pins
LED1 to LED5	O	LED Output Pin
GND	-	Ground Pin
OSC	I	Oscillator Input Pin A resistor is connected to this pin to determine the oscillation frequency

CIRCUIT DIAGRAM - KEY BOARD

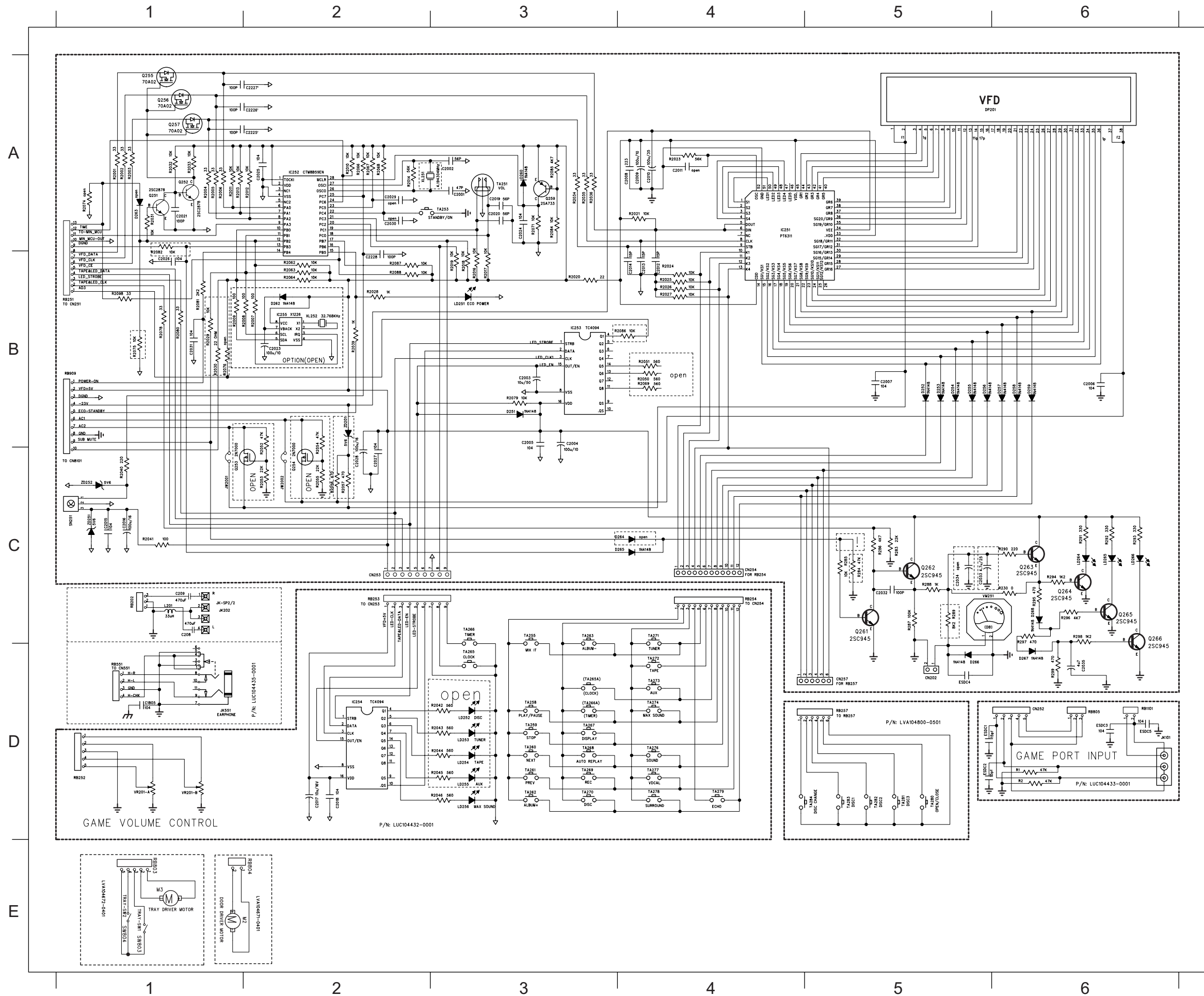

C1805	D1	R284	C5	SW803	E1
C2001	A3	R285	C5	SW804	E1
C2002	A3	R286	C5	TA251	A3
C2003	B3	R287	C5	TA253	A3
C2004	B3	R288	C5	TA255	C3
C2005	B3	R289	C5	TA258	D3
C2006	B6	R291	C6	TA259	D3
C2007	B5	R292	C6	TA260	D3
C2008	A4	R293	C6	TA261	D3
C2009	A4	R294	C6	TA262	D3
C2010	A4	R295	C6	TA263	C3
C2012	B4	R296	C6	TA265	D3
C2013	B4	R297	C6	TA265A	D3
C2014	B4	R298	C6	TA266	C3
C2015	C1	R299	D6	TA266A	D3
C2016	C1	R2001	A1	TA267	D3
C2017	D2	R2002	A1	TA268	D3
C2018	D2	R2003	A1	TA269	D3
C2019	A3	R2004	A1	TA270	D3
C2020	A3	R2005	A1	TA271	C4
C2021	A1	R2006	A1	TA272	D4
C2024	A3	R2010	A2	TA273	D4
C2025	A2	R2011	A1	TA274	D4
C2026	B1	R2012	A2	TA276	D4
C2027	C2	R2013	A1	TA277	D4
C2028	C2	R2014	A2	TA278	D4
C2031	B1	R2016	B3	TA279	D4
C2032	C5	R2017	B3	TA280	D5
C2033	C5	R2018	B3	TA281	D5
C2035	D6	R2019	B3	TA282	D5
C2225	A2	R2020	B3	TA283	D5
C2226	A2	R2021	A4	TA284	D5
C2227	A2	R2023	A4	VM251	C5
C2228	B2	R2024	B4	VR201-A	D1
CN202	D5	R2025	B4	VR201-B	D1
CN252	D6	R2026	B4	XL251	A2
CN253	C2	R2027	B4	ZD201	B2
CN254	C4	R2028	B1	ZD251	C1
CN257	D5	R2029	B2	ZD252	C1
D251	B3	R2030	B1		
D252	B5	R2031	A1		
D253	B5	R2032	A1		
D254	B5	R2033	A1		
D255	B5	R2034	A3		
D256	B5	R2035	A3		
D257	B6	R2036	A3		
D258	B6	R2039	B1		
D259	B6	R2040	C2		
D260	A3	R2041	C1		
D265	C4	R2046	D3		
D266	D5	R2056	C2		
D267	D6	R2057	C2		
D268	C6	R2062	B2		
DP201	A6	R2063	B2		
ESDC2	D5	R2064	B2		
ESDC5	D6	R2066	A2		
IC251	A4	R2067	A2		
IC252	A2	R2068	A2		
IC253	B3	R2071	A3		
IC254	D2	R2075	B1		
JK101	D6	R2078	B1		
JK551	D1	R2079	B3		
JW2001	C1	R2080	B1		
JW2002	C2	R2081	B1		
LD251	B3	R2082	B1		
LD256	D3	R2084	A3		
LD264	C6	R2085	A3		
LD265	C6	R2086	B4		
LD266	C6	R2087	B2		
M2	E2	R2088	B2		
M3	E1	R2098	B1		
Q251	A1	RB1101	D6		
Q252	A1	RB202	C1		
Q255	A1	RB251	B1		
Q256	A1	RB252	D1		
Q257	A1	RB253	C2		
Q259	A3	RB254	C4		
Q261	C5	RB257	D5		
Q262	C5	RB551	D1		
Q263	C6	RB803	E1		
Q264	C6	RB804	E2		
Q265	C6	RB805	D6		
Q266	C6	RB909	B1		
R230	C6	SN251	C1		

PCB LAYOUT - KEY BOARD (TOP)

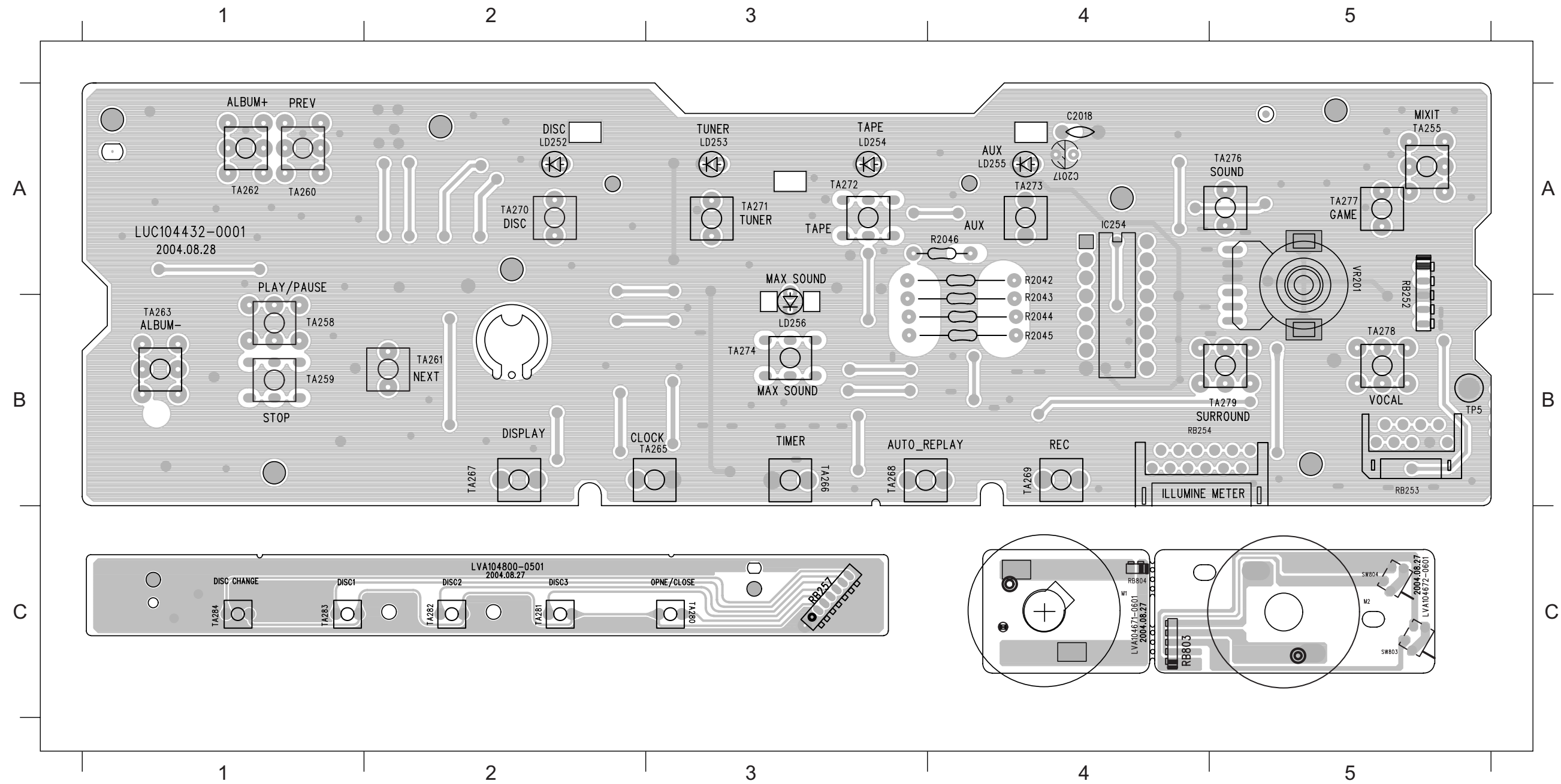

C2017	A4
C2018	A4
IC254	A4
LD256	B3
M1	C4
M2	C5
R2042	A4
R2043	B4
R2044	B4
R2045	B4
R2046	A4
RB252	A5
RB253	B5
RB254	B4
RB257	C3
RB803	C4
RB804	C4
SW803	C5
SW804	C5
TA255	A5
TA258	B1
TA259	B1
TA260	A1
TA261	B2
TA262	A1
TA263	B1
TA265	B3
TA266	B3
TA267	B2
TA268	B3
TA269	B4
TA270	A2
TA271	A3
TA272	A3
TA273	A4
TA274	B3
TA276	A5
TA277	A5
TA278	B5
TA279	B5
TA280	C3
TA281	C2
TA282	C2
TA283	C1
TA284	C1
TP5	B5
VR201	A5

PCB LAYOUT - GAME & MIC & PHONE BOARD (BOTTOM VIEW)

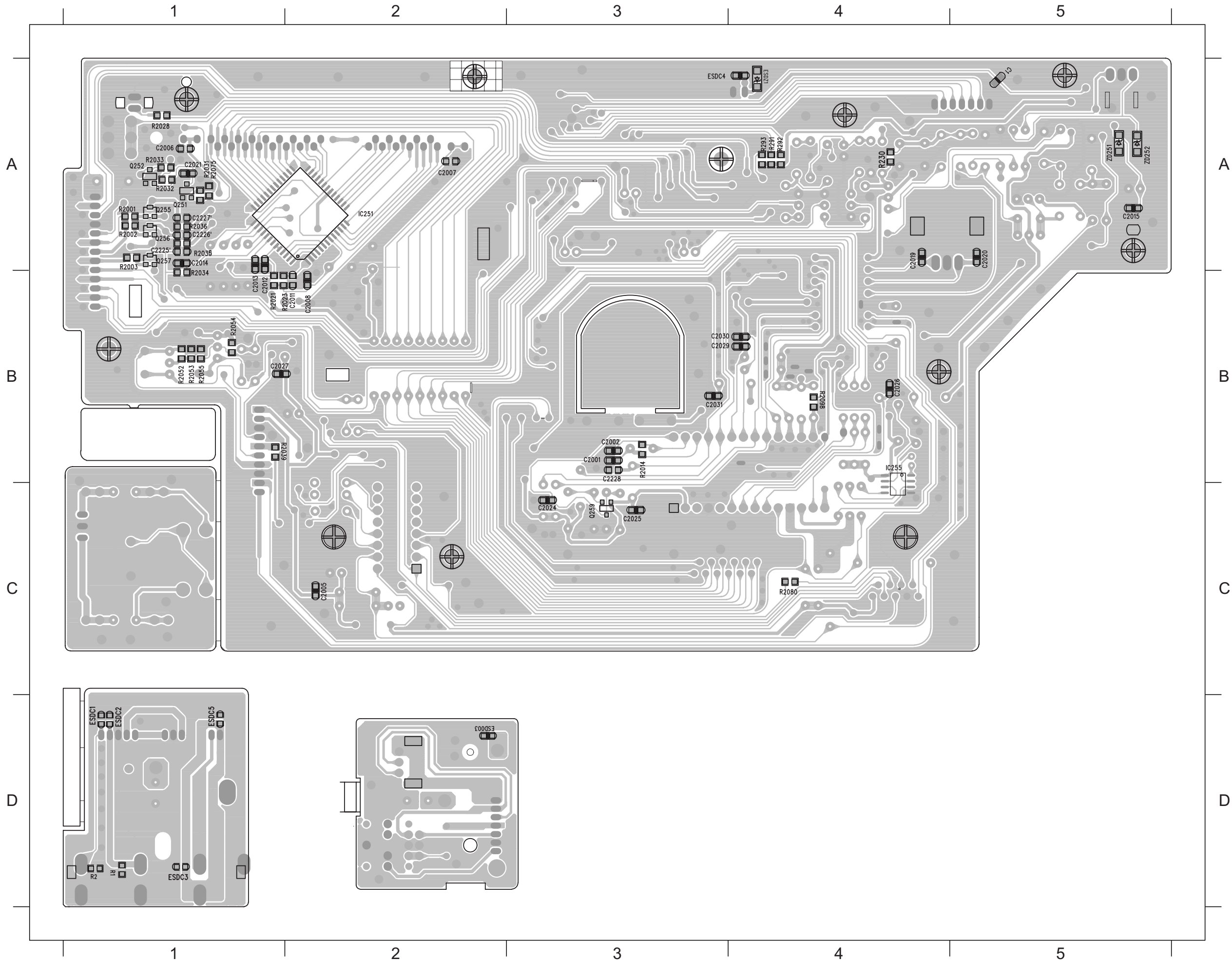

C2001	B3
C2002	B3
C2005	C2
C2006	A1
C2007	A2
C2008	B2
C2011	B2
C2012	B1
C2013	B1
C2014	A1
C2015	A5
C2019	A4
C2020	A5
C2021	A1
C2024	C3
C2025	C3
C2026	B4
C2027	B1
C2029	B3
C2030	B3
C2031	B3
C2225	A1
C2226	A1
C2227	A1
C2228	B3
ESDC2	D1
ESDC5	D1
IC251	A2
IC255	B4
Q251	A1
Q252	A1
Q255	A1
Q256	A1
Q257	A1
Q259	C3
R230	A4
R291	A4
R292	A4
R293	A4
R2001	A1
R2002	A1
R2003	A1
R2014	B3
R2021	B1
R2023	B1
R2028	A1
R2031	A1
R2032	A1
R2033	A1
R2034	B1
R2035	A1
R2036	A1
R2039	B1
R2052	B1
R2053	B1
R2054	B1
R2055	B1
R2075	A1
R2080	C4
R2098	B4
ZD251	A5
ZD252	A5

ELECTRIC PARTS - KEY BOARD

SW803	9940 000 00871	TACT SW DIA1.7MM
SW804	9940 000 00871	TACT SW DIA1.7MM
TA280	9940 000 00872	TACT SW 50MA 12V
TA281	9940 000 00872	TACT SW 50MA 12V
TA282	9940 000 00872	TACT SW 50MA 12V
TA283	9940 000 00872	TACT SW 50MA 12V
TA284	9940 000 00872	TACT SW 50MA 12V

ELECTRIC PARTS - VFD+CONTL+GAME+MIC+PHONE BOARD

DP201	9940 000 00879	VFD 46X26MM HNA-11LS11T	TA270	9940 000 00872	TACT SW 50MA 12V
IC251	9940 000 00907	IC 52 PIN TP6311QH	TA271	9940 000 00872	TACT SW 50MA 12V
IC252	9940 000 00923	IC 28 PIN CTM8059EN	TA272	9940 000 00872	TACT SW 50MA 12V
IC253	9940 000 00922	IC 16 PIN CD4094B	TA273	9940 000 00872	TACT SW 50MA 12V
IC254	9940 000 00922	IC 16 PIN CD4094B	TA274	9940 000 00872	TACT SW 50MA 12V
JK101	9940 000 00965	RCA JACK 3P WT-RD-YL AXIAL	TA276	9940 000 00872	TACT SW 50MA 12V
JK301	9940 000 00964	PHONE JACK D3.5 11P	TA277	9940 000 00872	TACT SW 50MA 12V
JK551	9940 000 00964	PHONE JACK D3.5 11P	TA278	9940 000 00872	TACT SW 50MA 12V
LD251	9940 000 00878	LED 3 DIA RED ROUND	TA279	9940 000 00872	TACT SW 50MA 12V
LD266	9940 000 00018	LED	VR201	9940 000 00885	CONTROL ROTRY 20KB
Q251	9940 000 00915	XISTR NPN 2SC1623	VR301	9940 000 00882	CONTROL ROTRY 50KB
Q252	9940 000 00915	XISTR NPN 2SC1623	XL251	9940 000 00966	CRYSTAL 4.194304MHZ
Q253	9940 000 00886	MOS FET 2N7000 60V 200MA			
Q254	9940 000 00886	MOS FET 2N7000 60V 200MA			
Q255	9940 000 00914	FET 2N7002LT1			
Q256	9940 000 00914	FET 2N7002LT1			
Q257	9940 000 00914	FET 2N7002LT1			
Q259	9940 000 00921	XISTR PNP 2SA812 HFE:200-400			
Q261	4822 130 41198	2SC945P			
Q262	4822 130 41198	2SC945P			
Q264	4822 130 41198	2SC945P			
Q265	4822 130 41198	2SC945P			
Q266	4822 130 41198	2SC945P			
SN251	9940 000 00926	IRT SENSOR GP1UX501QS			
TA251	9942 000 00881	ENCODER			
TA253	9940 000 00872	TACT SW 50MA 12V			
TA255	9940 000 00872	TACT SW 50MA 12V			
TA258	9940 000 00872	TACT SW 50MA 12V			
TA259	9940 000 00872	TACT SW 50MA 12V			
TA260	9940 000 00872	TACT SW 50MA 12V			
TA261	9940 000 00872	TACT SW 50MA 12V			
TA262	9940 000 00872	TACT SW 50MA 12V			
TA263	9940 000 00872	TACT SW 50MA 12V			
TA265	9940 000 00872	TACT SW 50MA 12V			
TA266	9940 000 00872	TACT SW 50MA 12V			
TA267	9940 000 00872	TACT SW 50MA 12V			
TA268	9940 000 00872	TACT SW 50MA 12V			
TA269	9940 000 00872	TACT SW 50MA 12V			

Note: Only these parts mentioned in the list are normal service parts.

TUNER ADJUSTMENT TABLE

TUNER BOARD (9940 000 00873)

TABLE OF CONTENTS

Tuner Adjustment Table 6-1
 Circuit Diagram 6-2
 PCB Layout Top View 6-3
 PCB Layout Bottom View 6-4

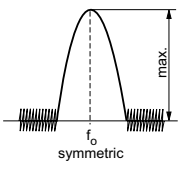
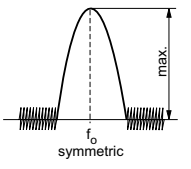
Waverange	Input frequency	Input	Tuned to	Adjust	Output	Scope/Voltmeter
<i>VARICAP ALIGNMENT</i>						
FM 87.5 - 108MHz (50kHz grid)			108MHz	check		7.5V ± 1V
			87.5MHz	check		1.4V ± 0.2V
MW 531-1602kHz (10kHz grid) (21L / 21L / 37S)			1602KHz	check		7.2V ± 1V
			531KHz	T005		1.1V ± 0.2V
<i>FM - RF</i>						
FM	108MHz		106MHz	VC001	MAX	MAX
	87.5MHz	mod=1kHz Δf=±22.5kHz	90.1MHz	L001		
<i>AM IF</i>						
AM	450kHz			T001 T002	MAX	
AM AFC MW	Connect pin 6 of IC001 (AM Osc.) with short wire to ground (pin 4)	Δf = ±15kHz V _{RF} = 3mV		T003		
		ΔV=mV				
<i>AM RF ³⁾</i>						
MW	1404kHz		1404kHz	VC001	MAX	
	612kHz		612kHz	T006		

Use Service Testprogram. By selecting the TUNER TEST test frequencies will be stored as preset frequencies automatically.

1) If sensitivity of frequency counter is too low adjust to max. channel separation (input signal: stereo left 90% + 9%, adjust output on right channel to minimum)

2) RC network serves for damping the IF-filter while adjusting the other one.

3) For AM RF adjustments the original frame antenna has to be used!

TUNER ADJUSTMENT TABLE

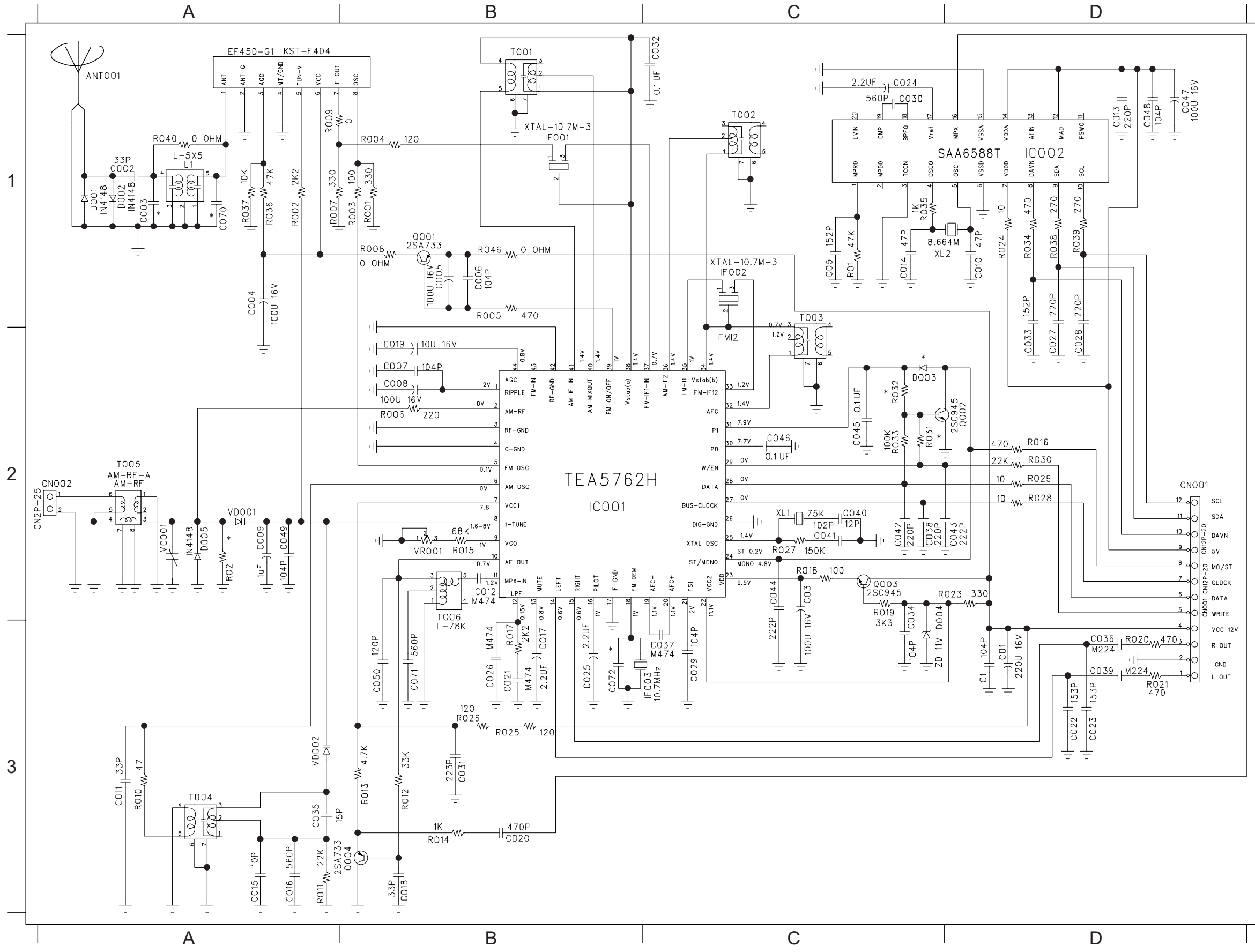

ANT001	A1	R01	C1
C1	D3	R001	B1
C01	D3	R002	A1
C03	C2	R003	B1
C05	C1	R004	B1
C002	A1	R005	B1
C004	A1	R006	B2
C005	B1	R007	A1
C006	B1	R008	B1
C007	B2	R009	A1
C008	B2	R010	A3
C009	A2	R011	A3
C010	D1	R012	B3
C011	A3	R013	B3
C012	B2	R014	B3
C013	D1	R015	B2
C014	C1	R016	D2
C015	A3	R017	B3
C016	A3	R018	C2
C017	B3	R019	C2
C018	B3	R020	D3
C019	B2	R021	D3
C020	B3	R023	D2
C021	B3	R024	D1
C022	D3	R025	B3
C023	D3	R026	B3
C024	C1	R027	C2
C025	B3	R028	D2
C026	B3	R029	D2
C027	D2	R030	D2
C028	D2	R033	C2
C029	C3	R034	D1
C030	C1	R035	C1
C031	B3	R036	A1
C032	B3	R037	A1
C033	D2	R038	D1
C034	C2	R039	D1
C035	A3	R040	A1
C036	D3	R046	B1
C037	C3	T001	B1
C038	C2	T002	C1
C039	D3	T003	C1
C040	C2	T004	A3
C041	C2	T005	A2
C042	C2	T006	B2
C043	D2	VC001	A2
C044	C2	VD001	A2
C045	C2	VD002	A3
C046	C2	VR01	B2
C047	D1	XL1	C2
C048	D1	XL2	C1
C049	A2		
C050	B3		
C071	B3		
CN001	D2		
CN002	A2		
D001	A1		
D002	A1		
D004	C2		
D005	A2		
EF450-G1	A1		
IC001	B2		
IC002	D1		
IF001	B1		
IF002	C1		
IF003	C3		
Q001	B1		
Q002	D2		
Q003	C2		
Q004	B3		

CIRCUIT DIAGRAM - TUNER BOARD (TOP VIEW)

ANT001	A2	C010	D2	C029	C1	C043	D1	D001	A1	Q003	D1	T004	C1	XL2	C2
C01	D1	C014	D2	C030	C2	C044	D2	D002	A2	R01	D2	T005	B1		
C03	D1	C017	C1	C033	D2	C045	C2	D004	D1	R005	C2	T006	C1		
C05	C2	C019	B2	C036	D1	C046	C2	IC001	C2	R024	D2	VC001	B1		
C004	B1	C024	D2	C037	C1	C047	D2	IF001	B2	R035	D2	VD001	C1		
C005	B2	C025	C1	C038	D1	C048	D2	IF002	C2	T001	B2	VD002	C1		
C008	C1	C027	D2	C039	D1	CN001	D2	IF003	C1	T002	C2	VR001	D1		
C009	C1	C028	D2	C042	D1	CN002	A1	Q002	C2	T003	C2	XL1	C2		

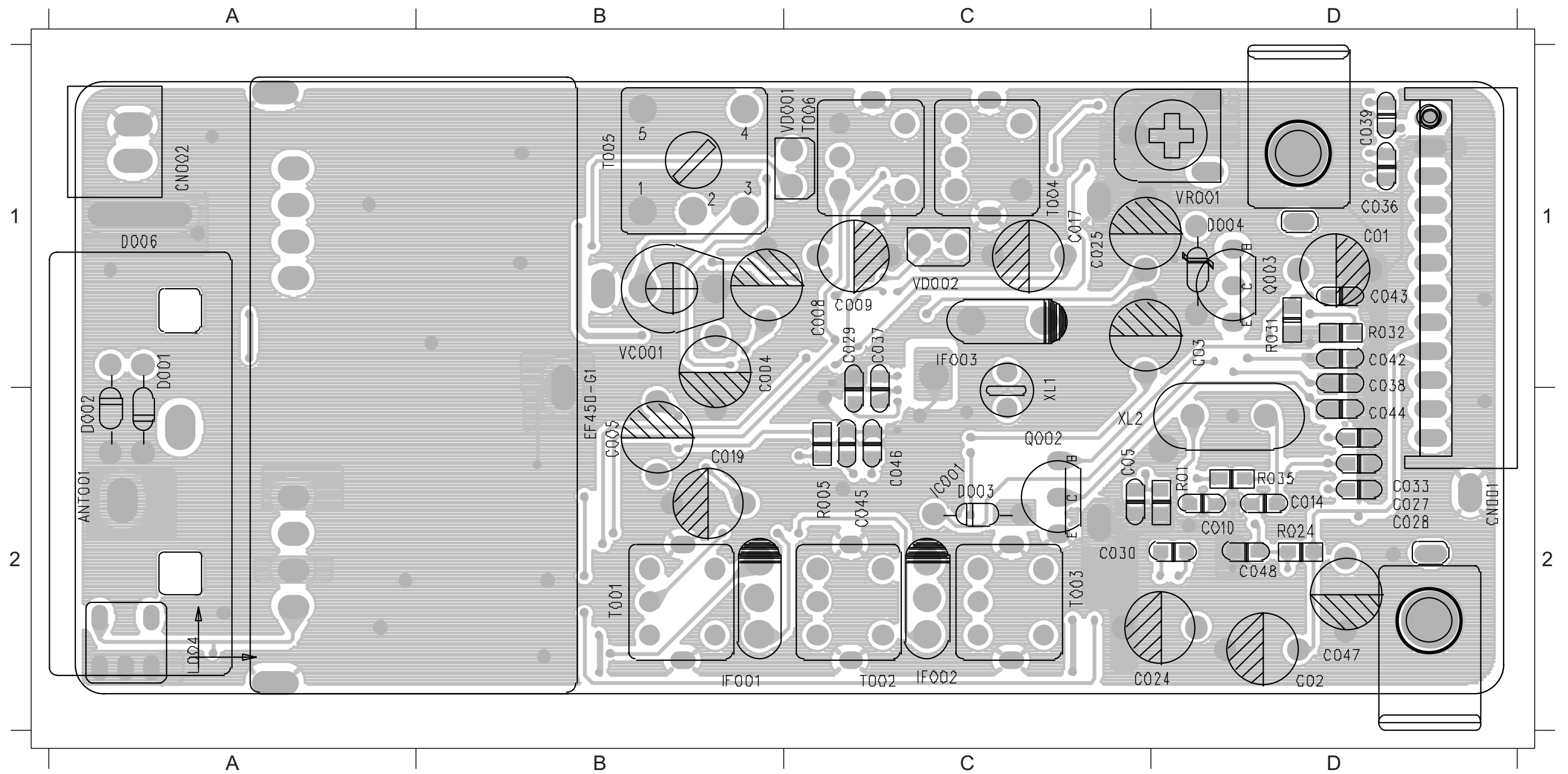

PCB LAYOUT - TUNER BOARD (BOTTOM VIEW)

C1	D1	C016	C1	C032	B2	D005	B1	R002	A1	R011	C1	R019	D1	R029	D1	R040	A2	VR001	D1
C002	A2	C018	A2	C034	D1	IC001	C2	R003	A1	R012	B2	R020	D1	R030	D1	R046	B2	XL2	D2
C006	B2	C020	B2	C035	C1	IC002	D2	R004	B2	R013	B2	R021	D1	R033	D1	T002	C2		
C007	B1	C021	B1	C040	C1	Q001	B2	R006	B1	R014	B2	R023	D1	R034	D2	T003	C2		
C011	C1	C022	C1	C041	C2	Q002	C2	R007	B2	R015	D1	R025	B2	R036	A2	T004	C1		
C012	C1	C023	C1	C049	C1	Q003	D1	R008	A1	R016	D2	R026	B2	R037	A2	T006	C1		
C013	D2	C026	B1	C050	B2	Q004	A2	R009	B2	R017	B1	R027	C2	R038	D2	VD001	C1		
C015	C1	C031	B2	C071	C1	R001	A1	R010	C1	R018	C1	R028	D1	R039	D2	VD002	C1		

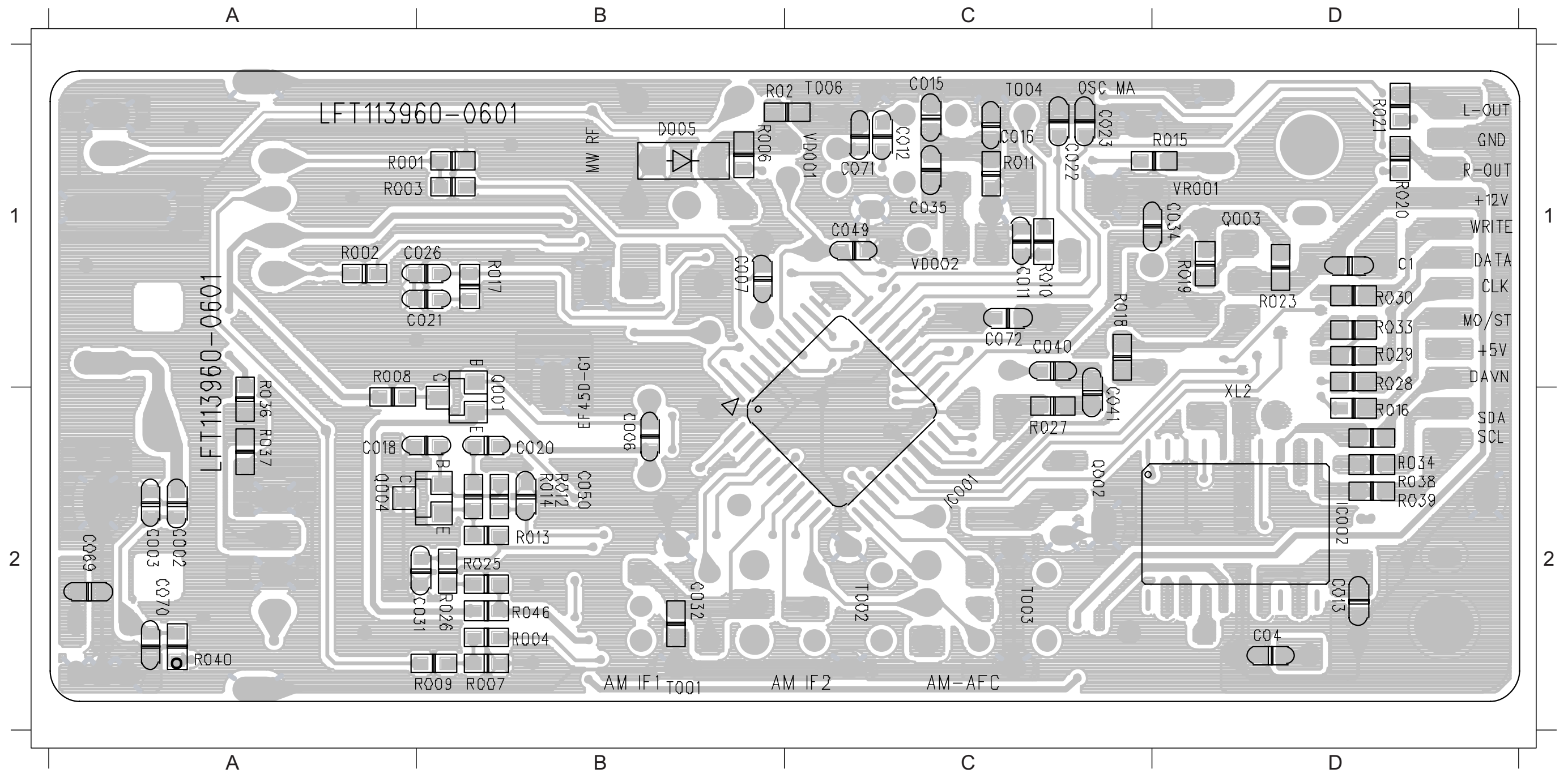

MAIN BOARD

TABLE OF CONTENTS

- IC Internal Diagram 7-1
- Circuit Diagram - Main Part 7-2
- Mapping 7-3
- Circuit Diagram - Servo Part 7-4
- Circuit Diagram - Tape Part 7-5
- Mapping 7-6
- PCB Layout Top View 7-7
- PCB Layout Bottom View 7-8
- Mapping 7-9
- Electrical Parts list 7-10

ES6698 INTERNAL IC DIAGRAM

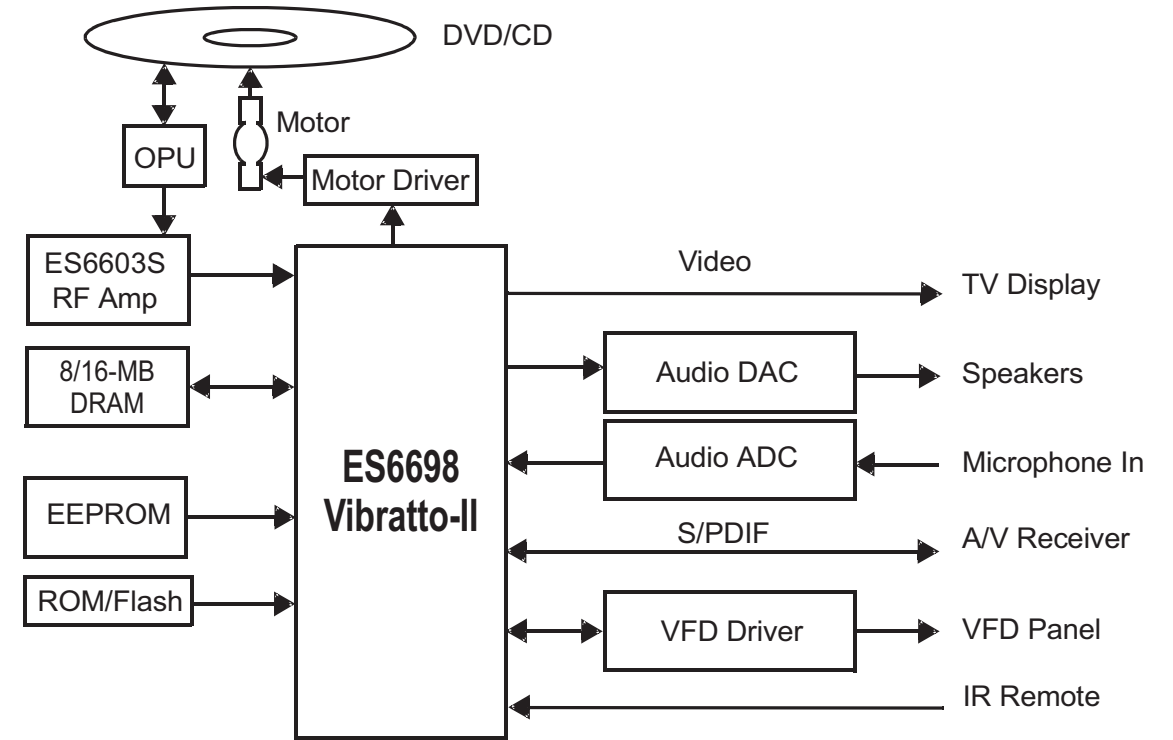

TDA8920 INTERNAL IC DIAGRAM

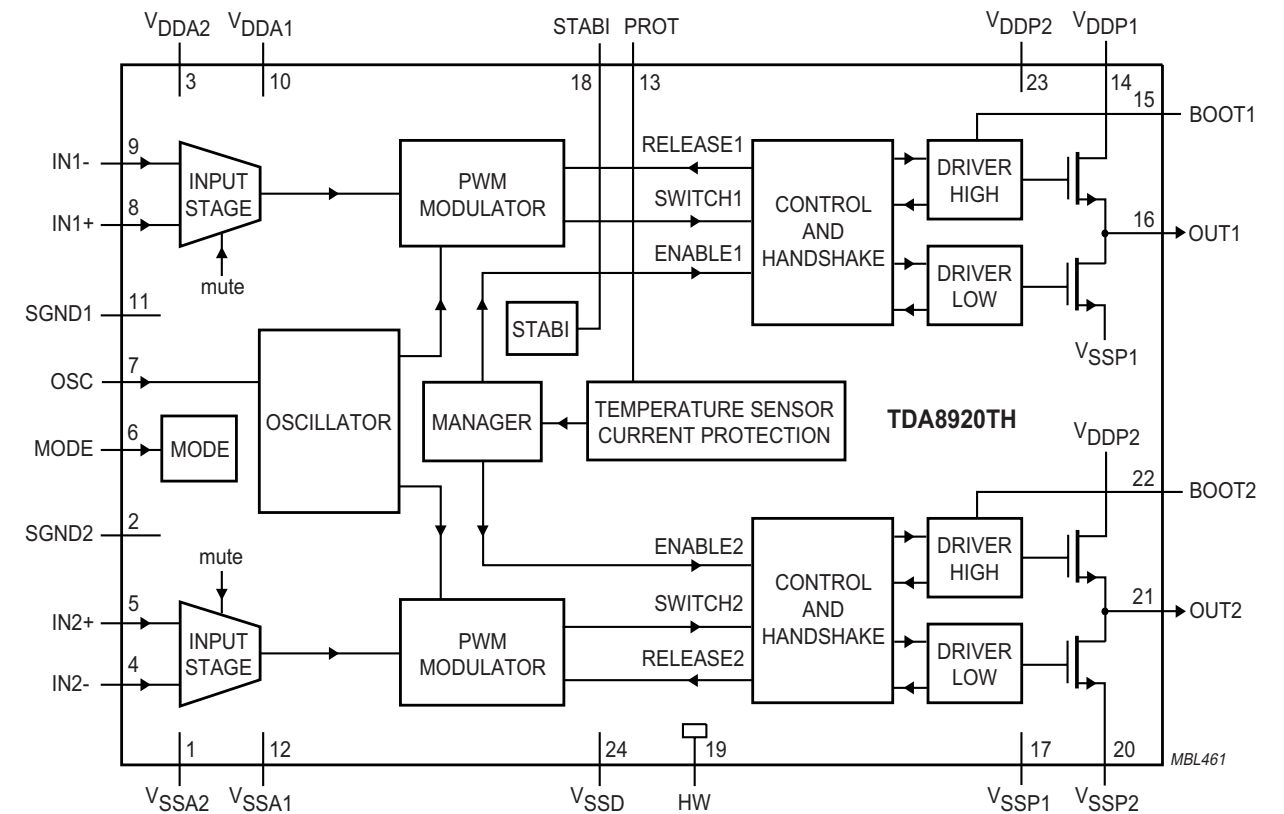

CIRCUIT DIAGRAM - MAIN BOARD

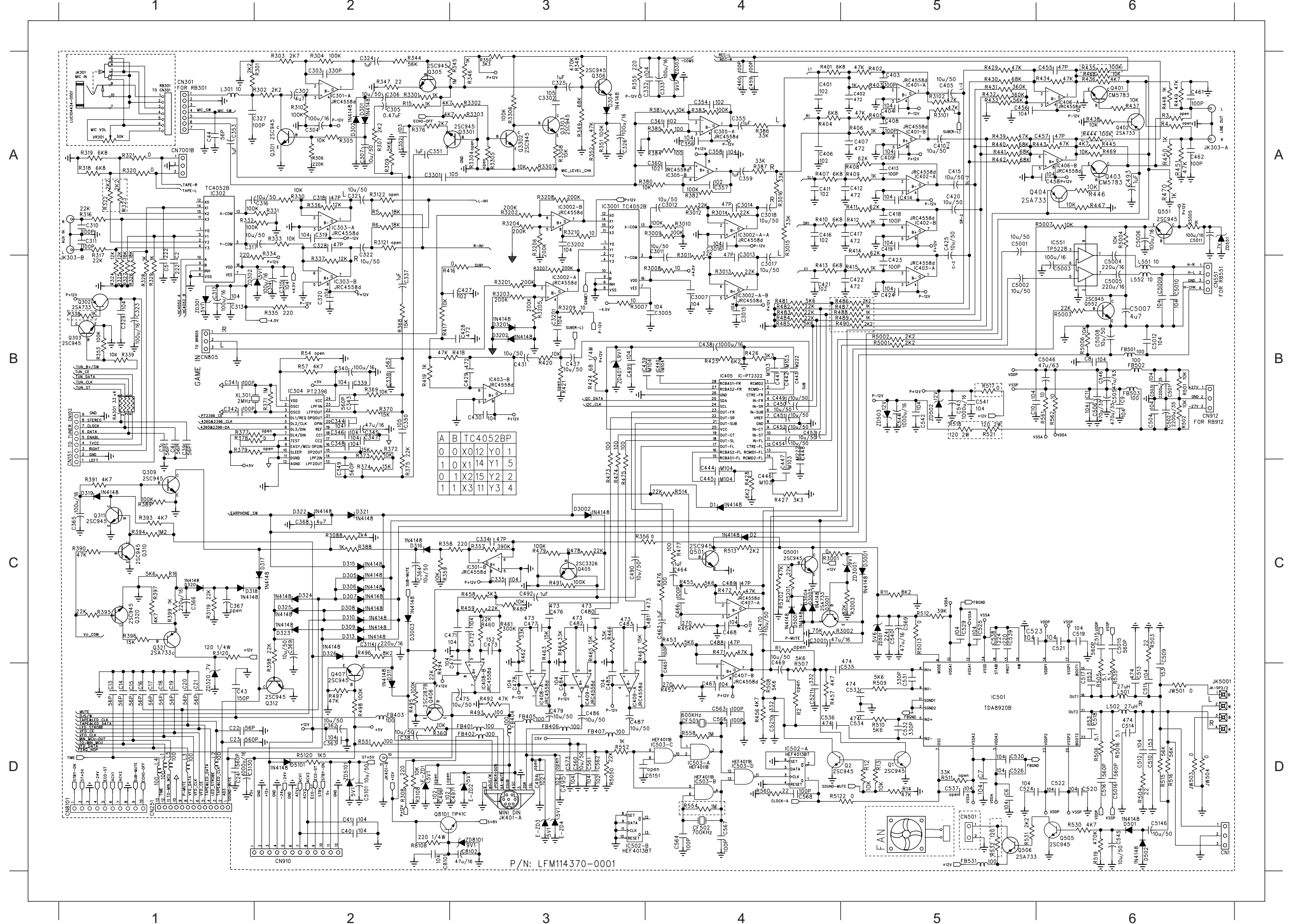

SCHEMATIC MAPPING - MAIN PART

C2	B1	C20	D1	C312	B1	C329	B1	CN8101	D1	D318	C1	D3202	B3	IC503-C	D4	R331	A2	R436	A6	R551	D2	
C3	B1	C21	D1	C313	B1	C332	A4	D1	C4	D319	C1	D5001	C4	IC503-D	D4	R332	A1	R437	A6	R552	D3	
C4	B1	C22	D1	C314	B2	C333	A4	D2	C4	D320	C1	D5101	D2	IC551	A6	R333	A2	R438	A6	R554	D4	
C5	B1	C23	D1	C315	B2	C334	C3	D301	A2	D321	C2	E-ZD1	D2	JK303-A	A6	R334	B2	R439	A5	R558	D4	
C6	D5	C24	D1	C316	A2	C335	C3	D302	A2	D322	C2	E-ZD2	D3	JK303-B	B1	R335	B2	R440	A5	R560	D4	
C7	D5	C39	B1	C317	A2	C337	B2	D304	A3	D323	C2	E-ZD3	D3	JK401-A	D3	R336	A2	R441	A5	R561	B6	
C8	B6	C40	D2	C318	A2	C338	B2	D305	C2	D324	C2	E-ZD4	D3	JK401-B	D2	R337	B2	R442	A5	R562	B6	
C9	B6	C41	D2	C319	A2	C339	B2	D306	C2	D325	C2	FB401	D3	JK5001	D6	R338	B1	R443	A6	R3001	C4	
C10	B5	C43	D1	C320	B2	C340	B2	D307	C2	D326	C2	FB402	D3	JW501	D6	R339	B1	R444	A6	R3002	C4	
C11	B6	C302	A2	C321	A2	C341	B1	D308	C2	D501	D6	FB403	D2	JW503	D6	R344	A2	R445	A6	R3003	C5	
C13	D1	C303	A2	C322	A2	C342	B1	D309	C2	D502	D6	FB404	D3	JW504	D6	R345	A3	R446	A6	R3007	B3	
C14	D1	C304	A2	C323	B1	C343	B2	D310	C2	D3001	C5	FB405	D3	L1	D1	R346	A3	R447	A6	R3008	B4	
C15	D1	C305	A2	C324	A2	C344	B2	D311	D2	D3002	C3	FB406	D3	L2	D1	R347	A2	R448	A6	R3009	A4	
C16	D1	C306	A2	C325	A3	C345	B2	D313	C2	D3003	C2	FB407	D3	L3	D1	R348	A3	R449	A6	R3010	A4	
C17	D1	C307	A2	C326	A3	C346	B2	D315	C2	D3004	C4	FB501	B6	L4	D1	R349	A3	R450	A6	R3011	A4	
C18	D1	C310	A1	C327	A2	C347	B2	D316	C2	D3005	C4	FB502	B6	L5	D1	R350	A3	R451	A6	R3012	A4	
C19	D1	C311	A1	C328	A2	C348	B2	D317	C2	D3201	B3	FB503	B6	L301	A1	R351	A3	R452	D4	R3013	B4	
C349	C2	C366	C1	C415	A5	C438	B4	FB531	D5	IC402-B	A5			L501	D6	R352	A3	R453	C4	R3014	A4	
C350	B2	C368	C2	C416	A4	C439	B3	IC3001	A3	IC403-A	B5			L502	D6	R353	B1	R454	C4	R3015	A4	
C351	A2	C369	C2	C417	A5	C440	B4	IC3002-A	B3	IC403-B	B3			L551	B6	R355	A3	R455	C4	R3016	A4	
C352	A2	C401	A4	C418	A5	C441	B4	IC3002-A-A	A4	IC405	B4			L552	B6	R356	C3	R456	D4	R3088	C2	
C353	A1	C402	A5	C419	A5	C442	B4	IC3002-A-B	B4	IC406-A	A6			Q1	D5	R357	C3	R457	D4	R3101	A5	
C354	A4	C403	A5	C420	A5	C443	B4	IC3002-B	A3	IC406-B	A6			Q2	D5	R358	C2	R458	C3	R3102	A5	
C355	A4	C404	A5	C421	B4	C444	C4	IC301-A	A2	IC407-A	C4			Q301	A2	R359	C2	R459	C3	R3108	D2	
C356	A4	C405	A5	C422	B5	C445	C4	IC301-B	C3	IC407-B	D4			Q302	B1	R360	D2	R460	C3	R3119	C1	
C357	A4	C406	A4	C423	B5	C446	C4	IC302	A1	IC408-A	D3			Q303	B1	R368	B2	R461	C3	R3120	C1	
C358	A4	C407	A5	C424	B5	C447	C4	IC303-A	A2	IC408-B	D3			Q305	A2	R369	B2	R462	C3	R3201	B3	
C359	A4	C408	A5	C425	A5	C448	B4	IC303-B	B2	IC409-A	D3			Q306	A3	R370	B2	R463	C3	R3202	A3	
C360	A4	C409	A5	C427	B3	C449	B4	IC304	B2	IC409-B	D3			Q309	C1	R371	B2	R464	C3	R3203	B3	
C361	A4	C410	A5	C428	B3	C450	B4	IC305-A	A4	IC501	D5			Q310	C1	R372	B2	R465	C3	R3204	A3	
C362	D2	C411	A4	C429	B3	C451	B4	IC305-B	A4	IC502-A	D4			Q311	C1	R373	B2	R466	C3	R3205	B3	
C363	D2	C412	A5	C430	B3	C452	B4	IC401-A	A5	IC502-B	D3			Q312	D2	R374	C2	R467	C3	R3206	A3	
C364	C2	C413	A5	C431	B3	C453	B4	IC401-B	A5	IC503-A	D4			Q320	C1	R375	C2	R468	A6	R3207	B3	
C365	C1	C414	A5	C437	B3	C454	B4	IC402-A	A5	IC503-B	D4			Q321	C1	R376	A2	R469	A6	R3208	A3	
C455	A6	C472	C3	C489	C4	C515	C6							Q401	A6	R378	B1	R470	A6	R3209	B3	
C456	A5	C473	C3	C490	C3	C516	D6							Q402	A6	R380	A4	R471	C4	R3210	A3	
C457	A6	C474	C3	C491	B3	C517	D6							Q403	A6	R381	A4	R472	C4	R3301	A2	
C458	A6	C475	D3	C492	C3	C518	D6							Q404	A6	R382	A4	R473	C3	R3302	A3	
C459	A4	C476	C3	C493	A6	C519	C6							Q405	C3	R383	A4	R474	C3	R3303	A3	
C460	A4	C477	C3	C501	B6	C520	D6							Q406	D2	R384	A4	R475	C3	R3306	A3	
C461	A6	C478	D3	C502	B6	C521	C6							Q407	D2	R385	A4	R476	C4	R3307	A3	
C462	A6	C479	D3	C503	B6	C522	D6							Q501	C4	R386	A4	R477	C4	R3308	A3	
C463	C4	C480	C3	C504	B6	C523	C5							Q505	D6	R387	A4	R478	C3	R5001	B5	
C464	C4	C481	C4	C505	B6	C524	D5							Q506	D5	R388	C2	R479	C3	R5002	B5	
C465	D4	C482	C3	C506	B6	C525	C5							Q551	A6	R389	C1	R480	C3	R5003	B6	
C466	C4	C483	C3	C509	D6	C526	D5							Q552	B6	R390	C1	R481	B4	R5004	A6	
C467	D4	C484	D3	C510	D6	C529	C5							Q3001	C4	R391	C1	R482	B4	R5005	A6	
C468	C4	C485	D3	C511	D6	C530	D5							Q3301	A3	R393	C1	R483	B4	R5006	B6	
C469	D4	C486	D3	C512	D6	C531	D5							Q3302	A3	R394	C1	R484	B4	R5007	A6	
C470	C4	C487	D3	C513	D6	C532	D5							Q3303	A3	R395	C1	R485	B4	R5013	C5	
C471	C3	C488	C4	C514	D6	C533	D5							Q5001	C4	R396	C1	R486	B5	R5016	D6	
C534	D5	C566	D4	C3130	D1	C5015	C6							Q8101	D2	R397	C1	R487	B5	R5120	D2	
C535	D5	C567	D4	C3201	B3	C5016	D6							R5	A2	R398	D2	R488	B5	R5122	D4	
C536	D4	C568	D4	C3202	A3	C5101	D2							R6	A2	R399	C1	R489	B5	R5201	C4	
C538	C5	C569	C5	C3301	A2	C5146	D6							R11	C5	R401	A4	R490	B5	R5202	C4	
C539	C5	C573	D3	C3302	A3	C8101	D2							R12	D5	R402	A5	R491	C3	R8108	D2	
C540	C5	C3001	C4	C5001	A5	C8102	D3							R13	D5	R403	A5	R492	D3	RA301	B1	
C541	B5	C3005	B4	C5002	B5	CF501	D4							R14	D5	R404	A4	R493	D3	XL301	B1	
C542	B5	C3007	B4	C5003	B6	CF502	D4							R15	A2	R405	A5	R494	D2	ZD301	B1	
C543	B5	C3011	A4	C5004	B6	CN151	B1							R16	C1	R406	A5	R495	D2	ZD302	B1	
C544	B5	C3012	A4	C5005	B6	CN251	D1							R57	B2	R407	A4	R496	C2	ZD303	A4	
C545	D6	C3013	A4	C5006	A6	CN301	A1							R301	A2	R408	A5	R497	D2	ZD320	D1	
C546	B6	C3014	A4	C5007	B6	CN501	D5							R302	A2	R409	A5	R498	D2	ZD401	B3	
C560	D3	C3015	B4	C5008	B6	CN551	B6							R303	A2	R410	A4	R501	B6	ZD501	C5	
C561	D3	C3016	A4	C5009	B6	CN805	B1							R304	A2	R411	A5	R502	B6	ZD502	B5	
C562	D3	C3017	B4	C5010	B6	CN910	D2							R305	A2	R412	A5	R503	C6	ZD503	B5	
C563	D4	C3018	A4	C5011	A6	CN912	B6							R306	A2	R413	B4	R504	D6	ZD551	A6	
C564	D4	C3114	C2	C5012	B6	CN7001B	A1							R307	A2	R414	A5	R505	D6	ZD3001	C5	
															R308	D2	R415	B5	R506	D6	ZD5101	D2
															R309	A2	R416	B3	R507	D4	ZD8101	D3
															R310	A2	R417	B2	R508	D4		
															R316	A1	R418	B3	R509	D5		
															R317	B1	R419	B2	R510	D5		
															R318	A1	R420	B3	R512	C5		
															R319	A1	R424	B3	R513	C4		
															R320	A1	R425	B4	R514	C4		
															R321	A1	R426	B4	R515	D6		
															R322	A1	R427	C4	R516	D6		
															R323	A1	R428	C4	R517	B5		
															R324	B1	R429	A5	R518	B5		
															R325	B1	R430	A5	R519	D6		
															R326	B1	R431	A5	R521	B5		
															R327	B1	R432	A5	R530	D6		
															R328	B1	R433	A5	R531	D5		
															R329	B1	R434	A6	R532	D5		

CIRCUIT DIAGRAM - MAIN BOARD (SERVO PART)

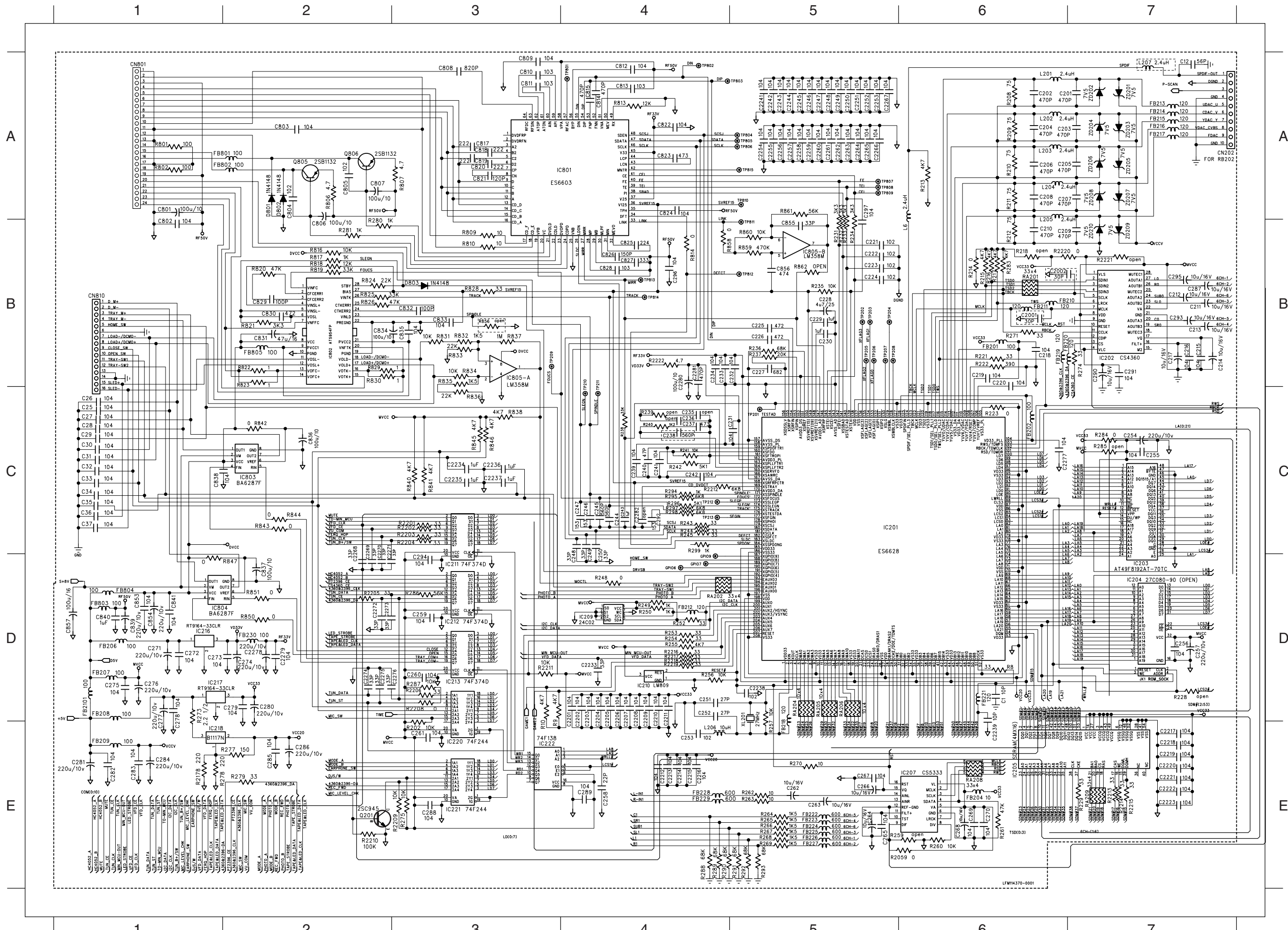

CIRCUIT DIAGRAM - MAIN BOARD (TAPE PART)

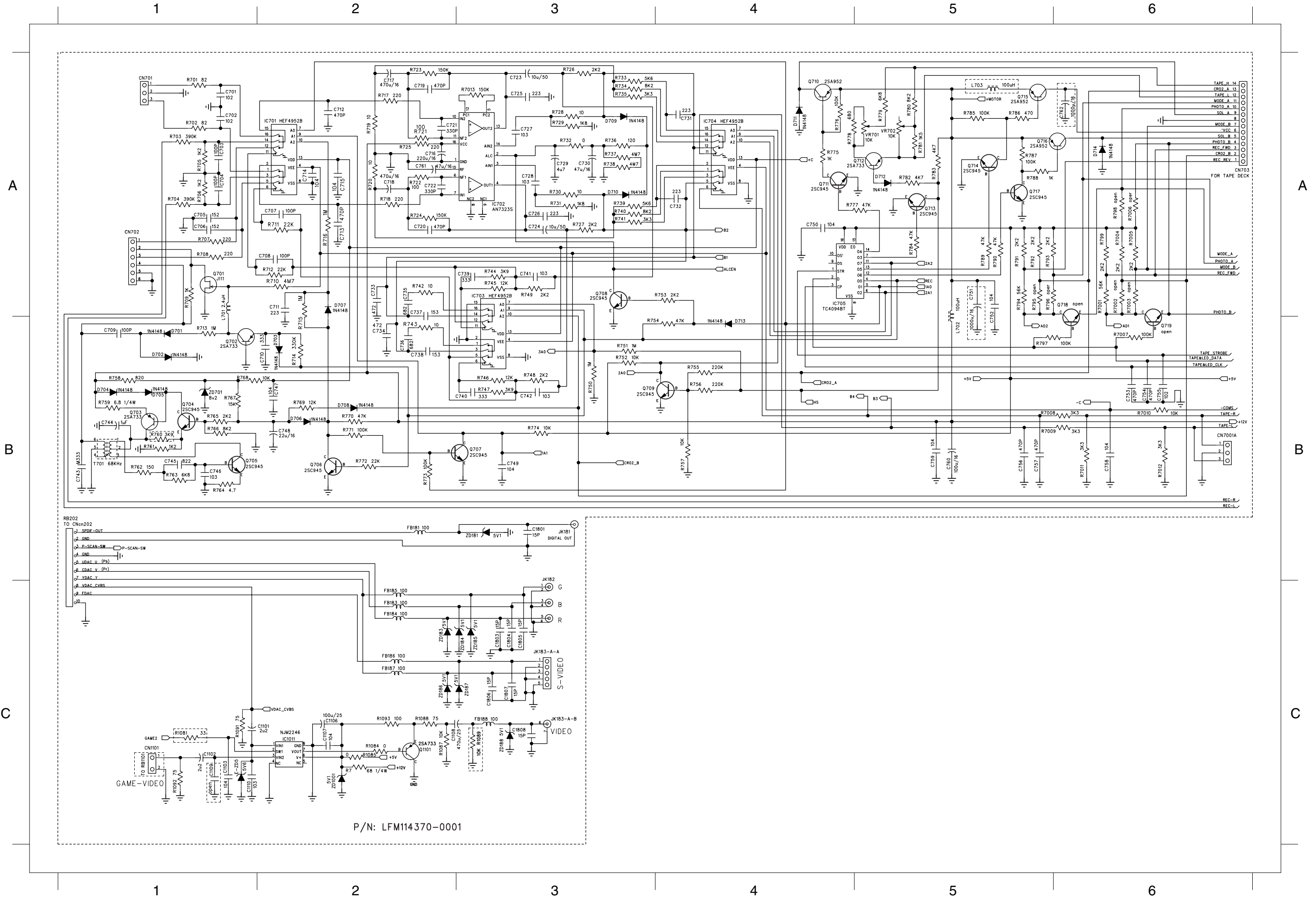

SCHEMATIC MAPPING - TAPE PART

C701	A1	D701	B1	R726	A3	R1092	C1
C702	A1	D702	B1	R727	A3	R1093	C2
C703	A1	D703	B2	R728	A3	R7001	A6
C704	A1	D704	B1	R729	A3	R7004	A6
C705	A1	D705	B1	R730	A3	R7005	A6
C706	A1	D706	B2	R731	A3	R7007	B6
C707	A2	D707	A2	R732	A3	R7008	B5
C708	A2	D708	B2	R733	A3	R7009	B5
C709	B1	D709	A3	R734	A3	R7010	B6
C710	B2	D710	A3	R735	A3	R7011	B6
C711	A2	D711	A4	R736	A3	R7012	B6
C713	A2	D712	A5	R737	A3	R7013	A3
C714	A2	D713	B4	R738	A3	RB202	B1
C715	A2	D714	A6	R739	A3	T701	B1
C716	A2	E-ZD05	C1	R740	A3	VR701	A5
C717	A2	FB181	B2	R741	A3	VR702	A5
C718	A2	FB183	C2	R742	A2	ZD181	B3
C719	A2	FB184	C2	R743	B2	ZD183	C2
C720	A2	FB185	C2	R744	A3	ZD184	C3
C721	A2	FB186	C2	R745	A3	ZD185	C3
C722	A2	FB187	C2	R746	B3	ZD186	C2
C723	A3	FB188	C3	R747	B3	ZD187	C3
C724	A3	IC1011	C2	R748	B3	ZD188	C3
C725	A3	IC701	A2	R749	A3	ZD701	B1
C726	A3	IC702	A3	R750	B3	ZD1001	C2
C727	A3	IC703	A3	R751	B3		
C728	A3	IC704	A4	R752	B3		
C729	A3	IC705	A4	R753	A4		
C730	A3	JK181	B3	R754	B4		
C731	A4	JK182	C3	R755	B4		
C732	A4	JK183-A-A	C3	R756	B4		
C733	A2	JK183-A-B	C3	R757	B4		
C734	B2	L701	A1	R758	B1		
C735	A2	L702	B5	R759	B1		
C736	B2	L703	A5	R760	B1		
C737	A2	Q701	A1	R761	B1		
C738	B2	Q702	B1	R762	B1		
C739	A3	Q703	B1	R763	B1		
C740	B3	Q704	B1	R764	B1		
C741	A3	Q705	B1	R765	B1		
C742	B3	Q706	B2	R766	B1		
C743	B1	Q707	B3	R767	B1		
C744	B1	Q708	A3	R768	B1		
C745	B1	Q709	B3	R769	B2		
C746	B1	Q710	A4	R770	B2		
C747	B2	Q711	A4	R771	B2		
C748	B2	Q712	A5	R772	B2		
C749	B3	Q713	A5	R773	B2		
C750	A4	Q714	A5	R774	B3		
C751	B5	Q715	A5	R775	A4		
C752	B5	Q716	A5	R776	A4		
C753	B6	Q717	A5	R777	A4		
C754	B6	Q719	B6	R778	A4		
C755	B6	Q1101	C2	R779	A5		
C756	B5	R7	C2	R780	A5		
C757	B5	R701	A1	R781	A5		
C758	B6	R702	A1	R782	A5		
C759	B5	R703	A1	R783	A5		
C760	B5	R704	A1	R784	A5		
C761	A2	R705	A1	R785	A5		
C762	A6	R706	A1	R786	A5		
C1101	C2	R707	A1	R787	A5		
C1102	C1	R708	A1	R788	A5		
C1103	C1	R709	A1	R789	A5		
C1106	C2	R710	A2	R790	A5		
C1107	C2	R711	A2	R791	A5		
C1108	C2	R712	A2	R792	A5		
C1801	B3	R713	B1	R793	A5		
C1803	C3	R714	B2	R794	A5		
C1804	C3	R715	B2	R795	A5		
C1805	C3	R716	A2	R796	A5		
C1806	C3	R717	A2	R797	B5		
C1807	C3	R718	A2	R799	A6		
C1808	C3	R719	A2	R1081	C1		
CN701	A1	R720	A2	R1084	C2		
CN702	A1	R721	A2	R1087	C2		
CN703	A6	R722	A2	R1088	C2		
CN1101	C1	R723	A2	R1089	C3		
CN7001AB6		R724	A2	R1091	C1		
		R725	A2				

LAYOUT MAPPING - TOP VIEW

C3	B4	C438	D4	C762	D2	CN301	A4	IC305	B4	R245	A1	R820	A2
C4	B4	C439	D5	C801	A1	CN501	C5	IC401	C4	R252	B1	R821	A2
C46	E3	C440	D5	C804	A1	CN551	D2	IC402	C4	R253	B1	R822	A2
C211	A3	C441	C5	C805	A1	CN701	D1	IC403	C4	R254	B1	R823	A2
C212	A3	C442	C5	C806	A1	CN702	D2	IC405	C5	R260	B2	R824	A2
C213	A3	C443	C5	C807	A1	CN703	D2	IC406	B5	R261	B2	R825	A2
C214	A3	C444	D4	C808	A2	CN801	A1	IC407	C4	R262	B3	R826	A2
C217	A3	C445	C4	C810	A2	CN805	B5	IC408	C5	R263	B3	R828	A2
C219	B2	C446	C4	C811	A2	CN810	A2	IC409	C5	R264	A4	R829	A2
C223	B2	C447	C4	C812	A2	CN910	E2	IC501	E4	R265	A4	R830	A2
C224	B2	C448	C4	C813	A2	CN912	E3	IC502	E3	R266	A4	R840	B1
C225	B2	C449	C5	C814	A2	CN1101	A4	IC503	E3	R267	A4	R841	B1
C226	B2	C450	C5	C815	A2	CN7001AE1	IC551	D2	R268	A4	R843	B3	
C227	B2	C451	C4	C817	A2	CN7001BA5	IC701	D2	R269	A4	R844	B3	
C228	B2	C452	C4	C818	A2	CN8101	C1	IC702	E2	R270	B2	R845	A1
C229	B2	C453	C4	C819	A2	D304	A4	IC703	E1	R273	B3	R846	A1
C237	B2	C454	C4	C820	A2	D305	D1	IC704	E1	R280	A1	R850	B3
C238	A2	C459	D1	C821	A2	D306	D1	IC705	D1	R281	A1	R851	B3
C240	A2	C460	D1	C823	A1	D307	D1	IC801	A1	R283	B2	R858	A2
C241	A2	C463	D4	C824	A1	D308	D1	IC802	A2	R284	C2	R859	A3
C242	A2	C464	D4	C825	A1	D309	D1	IC803	A3	R294	A1	R860	A3
C243	A2	C469	E3	C826	A1	D310	D1	IC804	A3	R295	A1	R861	A3
C244	A2	C470	E3	C827	A1	D313	C1	IC805	A3	R296	A1	R1089	A5
C245	A2	C475	C5	C828	A1	D315	D1	IC1011	A5	R297	A1	R2201	B4
C246	A2	C479	C5	C829	A2	D321	D1	IC3001	B5	R307	A4	R2202	B4
C247	A2	C486	C5	C830	A2	D322	D1	IC3002	B5	R308	C5	R2203	B3
C254	C2	C487	C5	C831	A2	D708	E1	IC3002-AB4	R309	A4	R2204	B4	
C257	C3	C490	D4	C832	A2	D711	D1	JK181	B5	R328	A5	R2205	C4
C262	B3	C492	C5	C833	A2	D714	D1	JK182	A5	R329	A4	R2206	C4
C263	B3	C493	B5	C834	A2	D803	A2	JK183-A	A5	R330	A4	R2213	B1
C264	B3	C501	D3	C835	A2	FB181	B5	JK303	B5	R334	A5	R2214	B1
C266	B3	C502	D3	C836	A3	FB188	A5	JK401	C5	R335	A5	R2215	C1
C268	B3	C505	E4	C837	A3	FB201	B2	JW501	D5	R336	A4	R2216	B1
C271	A1	C506	E4	C839	A1	FB202	C2	JW502	D5	R339	B4	R2217	B1
C274	A1	C509	D5	C840	A1	FB204	B2	JW503	D5	R348	A4	R2218	B1
C276	C1	C510	D5	C854	A1	FB206	A1	JW504	C5	R349	A4	R2219	B1
C277	B3	C517	E4	C855	A3	FB207	C1	JK5001	D5	R351	A4	R2220	B2
C280	C2	C518	E5	C856	A2	FB208	C3	L201	C2	R378	B4	R2221	B2
C281	C3	C519	D4	C857	A3	FB209	C3	L202	C2	R424	D4	R2222	A1
C284	C3	C520	D4	C1101	A5	FB210	B2	L203	C2	R456	E5	R3120	C1
C286	B2	C521	E4	C1102	A5	FB211	B2	L204	C2	R457	E4	R5013	E5
C287	A3	C522	E5	C1103	A5	FB212	B1	L205	C2	R470	B5	R5112	E4
C290	B3	C523	E5	C1106	A4	FB213	C2	L206	B1	R478	B5	R5113	E5
C293	A3	C524	E4	C1108	A5	FB214	C2	L207	C2	R479	B5	R5122	E4
C295	A3	C525	E4	C1808	B5	FB215	C2	L501	D4	R491	B5	R5123	E5
C296	A1	C526	E5	C2233	B1	FB216	C2	L502	D5	R507	E3	R5161	E4
C297	B2	C529	E4	C2234	A1	FB217	C2	L702	E2	R508	E3	R5162	E4
C302	A4	C530	E5	C2235	A1	FB218	B1	L703	D1	R509	E4	R7010	E1
C304	A4	C532	E5	C2239	C1	FB221	C1	Q306	A4	R510	E5	R8108	E2
C305	A4	C533	E4	C2242	A2	FB222	A3	Q405	B5	R511	E4	RA201	B1
C306	A4	C534	E5	C2243	A2	FB223	A3	Q406	C5	R512	E5	RA202	B2
C307	A4	C535	E4	C2248	A2	FB224	A3	Q501	D5	R513	E5	RA204	B1
C312	A5	C536	E5	C2263	C4	FB225	A3	Q505	E5	R514	D5	RA205	B1
C314	B5	C537	E4	C2270	B3	FB226	A3	Q506	E5	R518	D3	RA206	B1
C316	A4	C538	D5	C2274	C4	FB227	A3	Q701	D2	R521	D3	RA208	B2
C317	A5	C539	E4	C2277	C2	FB230	A1	Q703	E2	R552	E3	RA209	B1
C318	A4	C540	E5	C2278	A1	FB401	C5	Q704	E2	R560	E4	RA301	B4
C321	A4	C543	D4	C2280	A1	FB402	C5	Q705	E2	R561	E5	RB202	A5
C322	A4	C544	D3	C3001	E3	FB403	C5	Q710	D1	R562	E5	T701	D2
C323	B4	C545	D5	C3011	B4	FB404	C5	Q711	D1	R703	E1	VR701	D2
C324	A4	C546	D4	C3012	B5	FB405	C5	Q715	D1	R704	E1	VR702	D2
C325	A4	C560	E3	C3017	B4	FB406	C5	Q716	D1	R717	E2	XL201	B1
C326	A4	C561	E3	C3018	B4	FB407	C5	Q805	A1	R750	E1	XL301	B4
C333	D1	C562	E3	C3114	C2	FB502	D3	Q806	A1	R751	E1	ZD201	C2
C337	A4	C568	E4	C3130	E3	FB503	D3	Q8101	E3	R758	E2	ZD203	C2
C340	B4	C569	D5	C3202	B5	FB803	A1	R7	A4	R759	E2	ZD205	C2
C345	B4	C573	E3	C5001	C4	FB804	A1	R16	D1	R760	D2	ZD207	C2
C351	B4	C712	E2	C5002	C4	FB805	A2	R57	B4	R761	D2	ZD209	C2
C353	A4	C716	E2	C5003	C2	FB2101	C1	R213	C2	R765	E2	ZD551	D2
C355	B4	C717	E2	C5004	D2	IC201	C1	R214	B2	R766	E2	ZD701	E2
C359	B4	C718	E1	C5005	D2	IC202	B2	R215	B2	R767	E2	ZD8101	E2
C362	E2	C723	E2</										

LAYOUT MAPPING - BOTTOM VIEW

C1	B1	C282	C3	C485	B5	C2203	B1	D709	E2	R2	E3	R372	B4	R468	B5	R748	E1	R3204	B5
C2	A5	C283	C2	C488	C4	C2204	B1	D710	E1	R5	A3	R373	B4	R469	B5	R749	E1	R3205	B5
C5	B5	C285	C2	C489	D4	C2205	B2	D712	D1	R6	B4	R374	B4	R471	C4	R752	D1	R3206	B5
C6	E5	C288	C3	C491	D4	C2206	B2	D713	E1	R8	C1	R375	B4	R472	D4	R753	E1	R3207	B5
C7	E4	C289	C3	C494	C5	C2207	B2	D801	A1	R9	A1	R376	A4	R473	C4	R754	E1	R3208	B5
C8	E5	C291	B3	C495	C5	C2208	B2	D802	A1	R10	A1	R380	B4	R474	C4	R755	D1	R3209	B5
C9	D4	C292	A2	C496	C5	C2209	B1	D3001	E3	R11	D5	R381	B4	R475	C4	R756	D1	R3210	B5
C10	D4	C294	B3	C497	C5	C2210	B1	D3002	E5	R12	E3	R382	B4	R476	D4	R757	D1	R3301	A4
C11	D3	C303	A4	C503	D3	C2211	B1	D3003	C1	R13	E3	R383	B4	R477	D4	R762	E2	R3302	A4
C12	C2	C310	B5	C504	D3	C2212	B1	D3004	E5	R14	E3	R384	B4	R480	C5	R763	E2	R3303	A4
C13	B1	C311	B5	C511	D5	C2213	B2	D3005	E5	R15	A4	R385	B4	R481	C4	R764	E2	R3304	A4
C14	B1	C313	A5	C512	D5	C2214	B2	D3201	B5	R202	B3	R386	B4	R482	C4	R768	E2	R3305	A4
C15	B1	C315	B5	C513	D5	C2215	B2	D3202	B5	R208	C2	R387	B4	R483	C4	R771	E1	R3306	A4
C16	B1	C319	A4	C514	D5	C2216	B2	D5001	E5	R209	C2	R388	A4	R484	C5	R772	E1	R3307	A4
C17	B1	C320	A5	C515	D4	C2217	B1	D5101	E2	R210	C2	R389	D1	R485	C5	R773	E1	R3308	A4
C18	B1	C327	A4	C516	D5	C2218	B1	E-ZD1	C5	R211	C2	R390	D1	R486	C4	R774	E2	R5001	C4
C19	B1	C328	A5	C531	E4	C2219	B1	E-ZD2	C5	R212	C2	R391	D1	R487	C4	R775	D1	R5002	C4
C20	B1	C329	B4	C541	D4	C2220	B1	E-ZD3	C5	R222	B2	R393	D1	R488	C4	R776	D1	R5003	D2
C21	B1	C332	E1	C542	D3	C2221	B1	E-ZD4	C5	R223	B2	R394	D1	R489	C5	R778	D2	R5004	D2
C22	B1	C334	A4	C563	E3	C2222	B1	E-ZD5	A5	R229	B1	R395	D1	R490	C5	R779	D2	R5005	D2
C23	A1	C335	A4	C564	E3	C2223	B1	FB183	A5	R231	A2	R396	D1	R492	C5	R780	D1	R5006	D2
C24	A1	C338	B4	C566	E3	C2236	B1	FB184	A5	R232	A2	R397	D1	R493	C5	R781	D2	R5007	D2
C25	A3	C339	E3	C567	E3	C2237	B1	FB185	A5	R235	B2	R398	D1	R494	C5	R782	D1	R5016	E5
C26	A3	C341	B4	C701	D2	C2238	B1	FB186	A5	R248	A1	R399	C1	R495	C5	R783	D1	R5120	E2
C27	A3	C342	B4	C702	D1	C2249	C2	FB187	A5	R249	B1	R401	B4	R496	D2	R784	D1	R5201	E5
C28	A3	C343	B4	C703	D2	C2250	B3	FB219	B3	R250	B1	R402	C4	R497	C2	R785	D1	R5202	E5
C29	A3	C344	B4	C704	D1	C2251	B3	FB220	B3	R255	B1	R403	C4	R498	C1	R786	D1	R7001	D2
C30	A3	C346	B4	C705	D2	C2252	D2	FB228	B3	R256	B1	R404	B4	R501	D3	R787	D1	R7004	D2
C31	A3	C347	B4	C706	E2	C2253	B3	FB229	B3	R257	B1	R405	B4	R502	D3	R788	D1	R7005	D2
C32	A3	C348	B4	C707	E1	C2254	A2	FB501	D2	R271	B2	R406	B4	R503	D5	R791	D2	R7007	D1
C33	A3	C349	B4	C708	E2	C2255	A3	FB531	E5	R274	B3	R407	C4	R504	D5	R792	D1	R7008	D1
C34	A3	C350	B4	C709	D2	C2256	A3	FB801	A1	R275	B3	R408	C4	R505	E4	R793	D1	R7009	E1
C35	A3	C352	A4	C710	E1	C2258	A4	FB802	A1	R277	C2	R409	C4	R506	E5	R794	D1	R7011	D1
C36	A3	C354	B4	C711	E2	C2259	A3	IC209	B1	R278	B3	R410	B4	R515	D5	R795	D1	R7012	E1
C37	A3	C356	B4	C713	D1	C2260	A3	IC210	B1	R279	C3	R411	C4	R516	D5	R796	D1	R7013	E2
C39	B4	C357	B4	C714	E2	C2262	A2	IC216	A1	R286	C3	R412	C4	R519	D5	R797	D1	ZD181	B5
C40	E2	C358	B4	C715	E1	C2264	D2	IC217	B2	R287	B3	R413	C4	R530	D5	R799	D2	ZD183	A5
C41	E2	C360	B4	C719	E2	C2266	C5	IC218	C3	R288	A3	R414	C4	R531	D5	R801	A1	ZD184	A5
C42	A2	C361	B4	C720	E2	C2267	A2	L1	B1	R289	A3	R415	C4	R535	E4	R802	A2	ZD185	A5
C43	C5	C363	E3	C721	E2	C2268	B3	L2	A1	R290	A3	R416	B4	R551	E3	R813	A1	ZD186	A5
C44	A4	C401	A3	C722	E2	C2269	B3	L3	B1	R291	A3	R417	B4	R554	E3	R818	A2	ZD187	A5
C45	A4	C402	C4	C725	E2	C2271	B3	L4	B1	R292	A3	R418	C4	R558	E3	R831	A3	ZD188	A5
C47	E2	C403	C4	C726	E1	C2272	C4	L5	B1	R293	A3	R419	C4	R701	D2	R832	A3	ZD202	C2
C201	C2	C404	C4	C727	E2	C2273	C4	L6	B2	R298	A2	R420	C5	R702	D1	R833	A3	ZD204	C2
C202	C2	C406	C4	C728	E2	C2275	B3	L301	A4	R299	B2	R421	C5	R705	D2	R834	A3	ZD206	C2
C203	C2	C407	C4	C731	E1	C2276	B3	L551	D2	R301	A4	R425	D5	R706	E1	R835	A3	ZD208	C2
C204	C2	C408	C4	C732	E1	C2279	A1	L552	D2	R302	A4	R426	C5	R707	D2	R836	A3	ZD210	C2
C205	C2	C409	B4	C733	E1	C2281	A1	L701	D2	R303	A4	R427	C4	R708	D2	R837	A3	ZD301	A5
C206	C2	C411	C4	C734	E1	C3005	B5	Q1	E3	R304	A4	R428	C4	R709	D2	R838	A1	ZD302	B5
C207	C2	C412	C4	C735	E1	C3007	B5	Q2	E3	R305	A4	R429	B5	R710	D2	R842	A3	ZD303	D1
C208	C2	C413	C4	C736	E1	C3013	B4	Q201	B3	R306	A4	R430	B5	R711	E1	R847	A3	ZD320	C1
C209	C2	C414	C4	C737	E1	C3014	B4	Q301	A4	R310	A4	R431	B5	R712	E2	R1081	A5	ZD401	D4
C210	C2	C416	C4	C738	E1	C3015	B4	Q302	B4	R316	B5	R432	B5	R713	E2	R1084	A5	ZD501	D5
C215	B3	C417	C4	C739	E1	C3016	B4	Q303	B4	R317	B5	R433	B5	R714	E1	R1087	A5	ZD502	D4
C216	B3	C418	C4	C740	E1	C3201	B5	Q305	A4	R318	B5	R434	B5	R715	E2	R1088	A5	ZD503	D4
C218	B2	C419	C4	C741	E1	C3301	A4	Q309	D1	R319	B5	R435	B5	R716	E2	R1091	A5	ZD1001	A4
C220	B2	C421	C4	C742	E1	C3302	A4	Q310	D1	R320	A5	R436	B5	R718	E1	R1092	A4	ZD3001	E3
C221	B2	C422	C4	C745	E2	C5009	D2	Q311	D1	R321	A5	R437	B5	R719	E2	R1093	A4	ZD5101	E2
C222	B2	C423	C4	C746	E2	C5010	D2	Q312	D1	R322	B5	R438	B5	R720	E1	R2159	B3		
C230	B2	C424	C4	C747	E2	C5012	D2	Q320	D1	R323	B5	R439	B5	R721	E2	R2178	C2		
C231	B2	C427	C4	C749	E2	C5015	D4	Q321	C1	R324	B5	R440	B5	R722	E2	R2208	B3		
C232	B2	C428	C4	C750	E2	C5016	D5	Q401	B5	R325	B5	R441	B5	R723	E2	R2209	C3		
C233	B2	C429	C4	C753	D1	C8101	E2	Q402	B5	R326	B5	R442	B5	R724	E2	R2210	B4		
C234	B2	C430	C4	C754	D1	D1	E5	Q403	B5	R327	A5	R443	B5	R725	E2	R2211	B3		
C239	A2	C455	B5	C755	D1	D2	D5	Q404	B5	R331	A4	R444	B5	R726	E2	R2212	A2		
C248	A1	C456	B5	C756	E1	D301	A4	Q407	C1	R332	A5	R445	B5	R727	E1	R3001	E3		
C249	A2	C457	B5	C757	D1	D302	A4	Q551	D2	R333	A5	R446	C5	R728	E2	R3002	E3		
C250	A2	C458	B5	C802	A1	D311	D1	Q552	D2	R337	A5	R447	B5	R729	E2	R3003	E3		
C251	B1	C461	B5	C803	A1	D316	A4	Q702	E2	R338	B4	R448	B5	R730	E2	R3007	B5		
C252	B1	C462	C5	C809	A2	D317	C1	Q706	E1	R344	A4	R449	B5	R731	E2	R3008	B5		
C253	B1	C465	C4	C822	A1	D318	D1	Q707	E2	R345	A4	R450	B5	R732	E1	R3009	B5		
C255	C2	C466	C4	C838	A3	D319	D1	Q708	E1	R346	A4	R451	B5	R733	E1	R3010	B5		
C256	C1	C467	C4	C841	A3	D320	D1	Q709	D1	R347	A4	R452	C4	R734	E1	R3011	B4		
C258	C3	C468	C4	C853	A1	D323	D1	Q712	D2	R350	A4	R453	C4	R735	E1	R3012	B5		
C259	C3	C471	C5	C1107	A5	D324	D1	Q713	D1	R352	B4	R454	C4	R736	E1	R3013	B4		
C260	B3	C472	C5	C1109	A4	D325	D1	Q714	D1	R353	B4	R455	D4	R737	E1	R3014	B4		
C261	B3	C473	C5	C1110	A5	D326	D1	Q717	D1	R355	D1	R458	C5	R738	E1	R3015	C4		
C265	B3	C474	C5	C1801	B5	D501	D5	Q718	D1	R356	B5	R459	C4	R739	E1	R3016	B4		
C267	B3	C476	B5	C1803	A5	D502	D5	Q719	D2	R357	A4	R460	C5	R740	E1	R3088	A4		
C269	B3	C477	C5	C1804	A5	D701	E2	Q1101	A5	R358	A4	R461	C5	R741	E1	R3101	C5		
C270	B3	C478	B5	C1805	A5	D702	D2	Q3001	E3	R359	A4	R462	B5	R742	E1	R3102	C4		
C272	A1	C480	C5	C1806	A5	D703	E1	Q3301	A4	R360	C5	R463	C5	R743	E1	R3108	C5		
C273	A1	C481	B5	C1807	A5	D704	E2	Q3302	A4	R368	B4	R464	C5	R744	E1	R3119	D1		
C275	C1	C482	C5	C2001	B2	D705	E2	Q3303	A4	R369	B4	R465	C5	R745	E1	R3201	B5		
C278	B3	C483	C5	C2002	B2	D706	E1	Q5001	E5	R370	B4	R466	B5	R746	E1	R3202	B5		
C279	C2	C484	C5	C2201	B1	D707	E1	R1	E3	R371	B4	R467	B5	R747	E1	R3203	B5		

ELECTRIC PARTS - MAIN BOARD

CF501	9940 000 00822	RESONATOR 2PIN 600KHZ	IC803	9940 000 00855	IC 8PIN BA6287FE2
CF502	9940 000 00823	RESONATOR 2PIN 700KHZ	IC804	9940 000 00855	IC 8PIN BA6287FE2
CN253	9940 000 00824	FFC CABLE 9P P1.27MM 80MM	IC805	9940 000 00856	IC 8PIN LM358MX NS
CN254	9940 000 00825	FFC CABLE 12P P1.27MM 100MM	JK181	9965 000 17363	RCA JACK 1P W/GND P
IC1011	4822 209 60614	NJM2246M	JK182	9940 000 00857	RCA JACK 3P R-B-G
IC201	9940 000 00827	IC 208P ES6698FD W/DTS	JK183-A	9965 000 25153	RCA+DIN JK 1RCA+4P DIN YEL
IC202	9940 000 00828	IC 28PIN CS4360	JK303	9940 000 00859	RCA JACK 4P W-W/R-R AUDIO IN
IC203	9940 000 00829	IC 48PIN MX29LV160ABTC-70	JK401	9940 000 00861	RCA+DIN JACK 1RCA+8P DIN
IC205	9940 000 00831	IC 54PIN K4S641632H-UC 75	JK5001	9940 000 00862	SPK JACK 4P RED-WHT-BLK-BLK
IC207	9940 000 00832	IC CS5333 16PIN	L501	9940 000 00863	INDUCTOR 27UH 20% 6A
IC209	9940 000 00833	IC 8PIN M24C04-WMN6T EEPROM	L502	9940 000 00863	INDUCTOR 27UH 20% 6A
IC210	9940 000 00834	IC 3PIN LM809	Q701	9940 000 00864	FET J111TO92 40V 20MA
IC211	9940 000 00835	IC 20PIN 74F374D	RA201	9940 000 00865	RES ARRAY 4X33R 1/10W 5%
IC212	9940 000 00835	IC 20PIN 74F374D	RA202	9940 000 00865	RES ARRAY 4X33R 1/10W 5%
IC213	9940 000 00835	IC 20PIN 74F374D	RA204	9940 000 00858	CHIP ARRAY 10RX4 1/10 W 5%
IC216	9965 000 15887	IC RT9164-33CLR	RA205	9940 000 00858	CHIP ARRAY 10RX4 1/10W 5%
IC217	9965 000 15887	IC RT9164-33CLR	RA206	9940 000 00858	CHIP ARRAY 10RX4 1/10W 5%
IC218	9940 000 00837	IC 3PIN LD1117 ADJ	RA208	9940 000 00865	RES ARRAY 4X33R 1/10W 5%
IC220	9940 000 00838	IC 20PIN 74F244	RA209	9940 000 00865	RES ARRAY 4X33R 1/10W 5%
IC221	9940 000 00838	IC 20PIN 74F244	RA301	9940 000 00865	RES ARRAY 4X33R 1/10W 5%
IC222	9940 000 00839	IC 16PIN 74F138D	T701	9940 000 00866	OSC COIL REC 3MH
IC3001	9940 000 00841	IC 16PIN TC4052BFN	VR701	9940 000 00867	CNTL TRIMR 10KB 30%
IC3002	9940 000 00842	IC 8PIN JRC4558M	VR702	9940 000 00868	XSTAL 2.0MHZ +/-15PPM HC-49/U
IC301	9940 000 00842	IC 8PIN JRC4558M			
IC302	9940 000 00841	IC 16PIN TC4052BFN			
IC303	9940 000 00842	IC 8PIN JRC4558M			
IC304	9940 000 00844	IC 24PIN PT2396S			
IC305	9940 000 00842	IC 8PIN JRC4558M			
IC401	9940 000 00842	IC 8PIN JRC4558M			
IC402	9940 000 00842	IC 8PIN JRC4558M			
IC403	9940 000 00842	IC 8PIN JRC4558M			
IC405	9940 000 00845	IC 28PIN PT2322-S			
IC406	9940 000 00842	IC 8PIN JRC4558M			
IC407	9940 000 00842	IC 8PIN JRC4558M			
IC408	9940 000 00842	IC 8PIN JRC4558M			
IC409	9940 000 00842	IC 8PIN JRC4558M			
IC501	9940 000 00846	IC 24PIN TDA8920BTH			
IC502	5322 209 14477	HEF4013BT			
IC503	9940 000 00848	IC 14PIN HEF4011BT(D)			
IC551	9940 000 00849	IC 8PIN TP5228 DRIVER W/MUTE			
IC701	4822 209 32919	HEF4952BT			
IC702	9322 140 00668	IC SM AN7323S (MATJ)			
IC703	4822 209 32919	HEF4952BT			
IC704	4822 209 32919	HEF4952BT			
IC705	5322 209 11306	HEF4094BT			
IC801	9940 000 00853	IC 64PIN ES6603S			
IC802	9940 000 00854	IC 28PIN D5954			

Note: Only these parts mentioned in the list are normal service parts.

POWER BOARD

TABLE OF CONTENTS

IC Internal Block Diagram	8-1
Circuit Diagram	8-2
PCB Layout	8-3
Electrical Parts List	8-4

**IC INTERNAL BLOCK DIAGRAM
SMPS CONTROLLER - KA7500C**

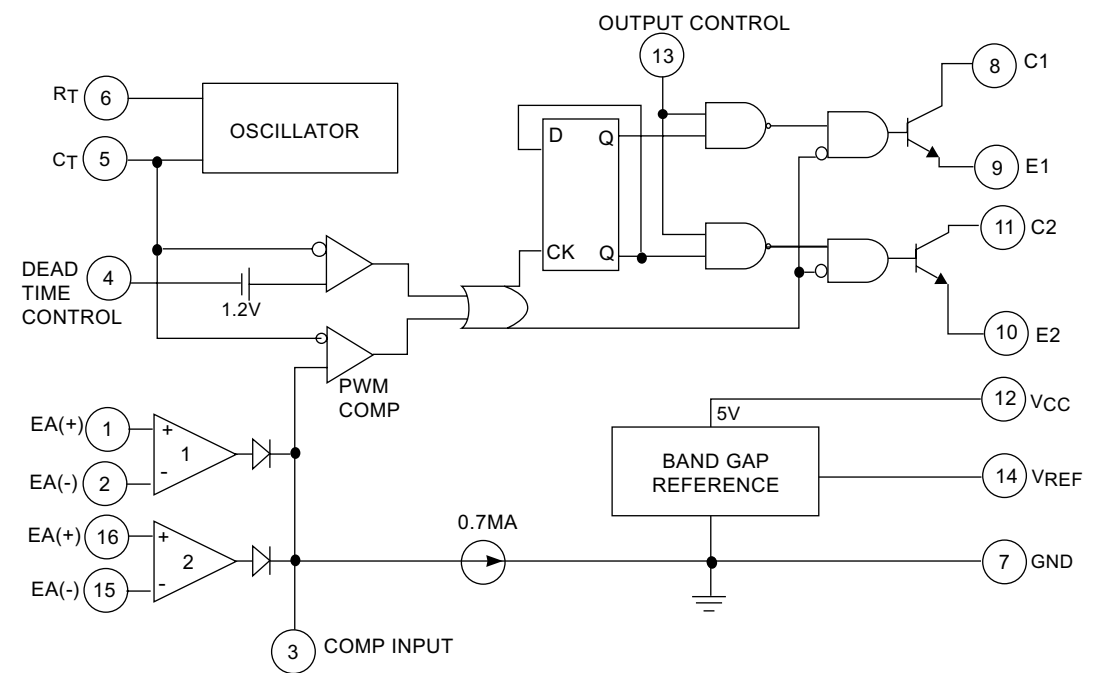

**IC INTERNAL BLOCK DIAGRAM
FAIRCHILD POWER SWITCH - KA5M02659RN**

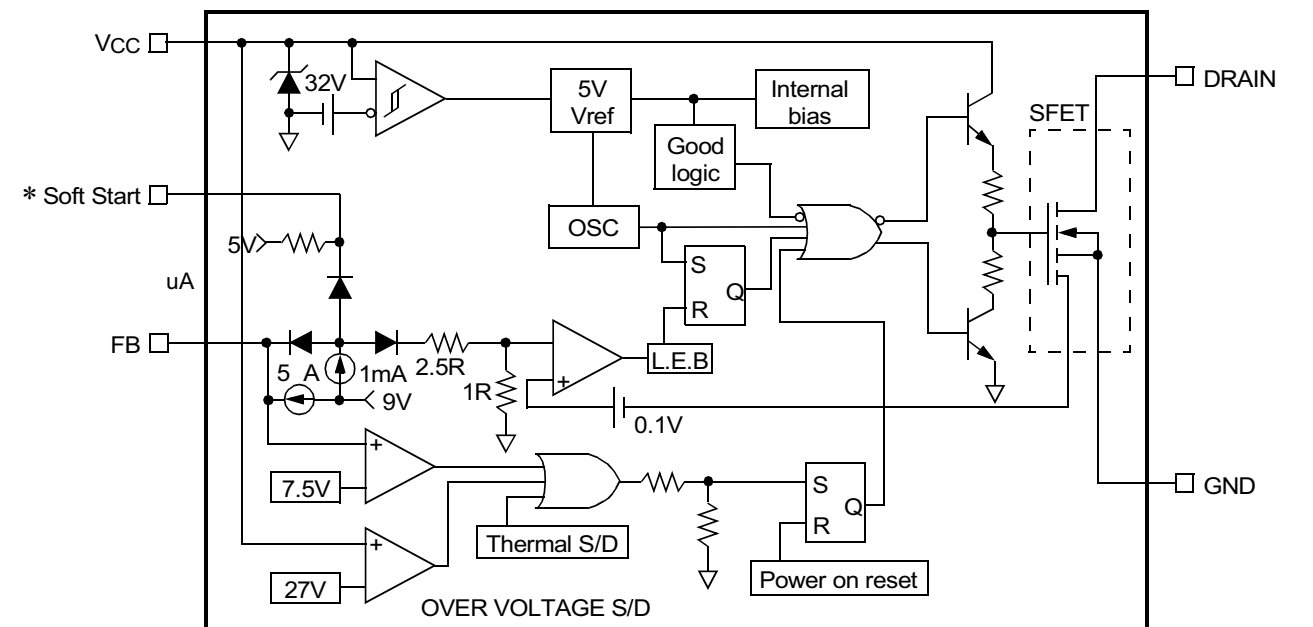

CIRCUIT DIAGRAM-POWER BOARD

BD901	A1	C908	A2	C919	D1	C953	A4	C963	B5	C978	D4	C988	A3	C998	C3	CN903	A1	D908	C2	D960	C3	IC954	B4	L959	D3	Q954	C3	R903	B1	R914	C2	R951	A4	R961	A5	R973	C4	R983	D4	R993	A5	TR902	B3
BF901	A2	C909	A2	C920	C1	C954	A4	C964	C5	C979	D3	C989	A3	C999	C3	CN951	A5	D909	A2	D962	C3	IC955	D3	L966	C3	Q955	C4	R904	A2	R915	C2	R952	A4	R962	B5	R974	C3	R984	D4	R994	A5	TR903	C3
BF902	B2	C911	C1	C921	A1	C955	B4	C965	C4	C980	D4	C990	C3	CN803A	A6	CN952	C5	D910	B2	F901	D1	L901	C1	Q901	A2	Q956	D4	R905	A2	R916	D2	R953	B4	R964	B3	R975	D3	R985	D3	R995	C1	TVR901	C1
BF903	B2	C912	D2	C922	B1	C956	B4	C966	C3	C981	B4	C991	D3	CN804A	A6	D901	A2	D951	A4	GT901	C1	L951	A4	Q902	B2	Q957	C4	R906	A2	R917	D2	R954	A4	R965	B3	R976	C4	R986	D3	R996	B4	ZD901	A2
C851	A6	C913	C2	C923	D3	C957	B4	C970	C4	C982	A3	C992	C3	CN806A	A6	D902	A2	D952	A5	IC901	C2	L952	A4	Q903	C2	Q959	D4	R907	B2	R918	C2	R955	B4	R966	B4	R977	D4	R987	D3	R997	B4	ZD902	B2
C852	A6	C914	D2	C926	A4	C958	A3	C972	C5	C983	A5	C993	C3	CN807A	A6	D903	B2	D953	B5	IC902	D3	L954	B3	Q904	C2	Q960	D4	R908	B2	R919	C2	R956	B4	R967	C4	R978	D4	R988	D3	R999	D4	ZD903	D2
C902	C1	C915	D3	C927	A4	C959	B5	C973	C3	C984	A5	C994	B3	CN808A	A6	D904	B2	D954	B3	IC951	A3	L955	C3	Q905	D2	R1	B1	R910	C2	R920	D2	R957	A5	R968	C5	R979	D4	R989	C4	RT901	B1	ZD904	D1
C903	C1	C916	D3	C928	B2	C960	B4	C974	C5	C985	A3	C995	A4	CN810A	A6	D905	C2	D955	B3	IC952	A3	L956	C4	Q951	B3	R2	A1	R911	C2	R921	C2	R958	A3	R969	C5	R980	D5	R990	D4	SW801	A6	ZD905	C2
C906	A1	C917	D3	C951	A4	C961	C4	C975	C4	C986	A3	C996	C3	CN901	D1	D906	C2	D958	C3	IC953-C	B5	L957	D3	Q952	B3	R3	B1	R912	C2	R922	B2	R959	B5	R971	B4	R981	D4	R991	D4	SW802	A6	ZD951	A4
C907	B1	C918	D1	C952	A4	C962	C4	C977	D3	C987	A3	C997	C4	CN902	B1	D907	C2	D959	C3	IC953-C	B5	L958	C5	Q953	C4	R902	A1	R913	C2	R923	B2	R960	A4	R972	B4	R982	D4	R992	C4	TR901	A3	ZD953	C4

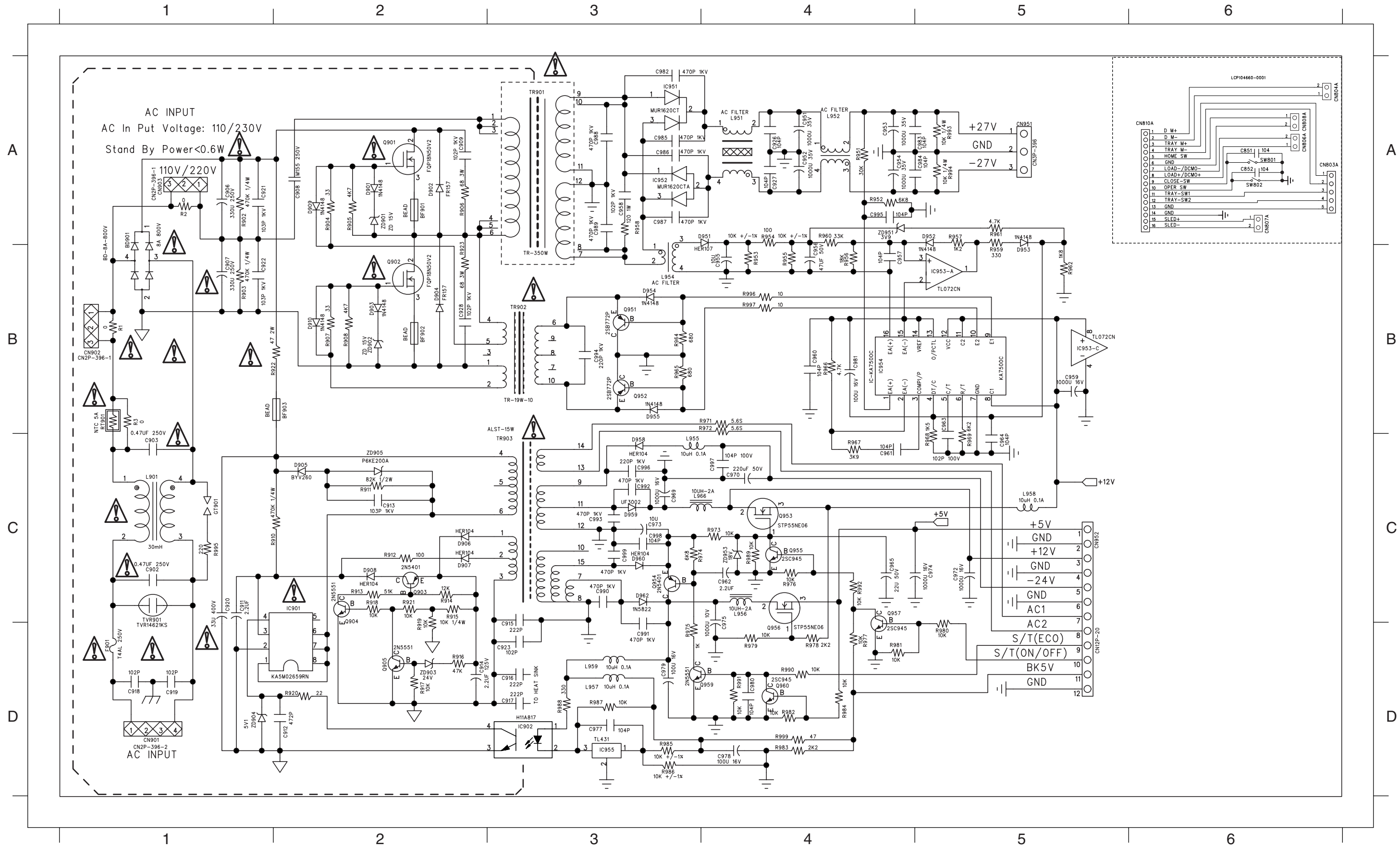

PCB LAYOUT - POWER BOARD

BD901	B1	C913	D3	C953	C7	C974	D6	C991	C5	CN902	B1	D953	C6	J801	D8	JMP12	C2	JMP30	A1	Q905	C3	R906	A3	R922	C2	R965	C4	R982	D6	R999	D6
C851	C8	C914	C3	C954	B7	C975	C5	C992	C5	CN903	A1	D954	B4	J802	C8	JMP13	D5	JMP31	A1	Q951	B4	R906A	A3	R923	B3	R966	B6	R983	D7	RT901	B1
C852	C8	C915	B4	C955	B5	C977	D5	C993	C5	CN951	D7	D955	B4	J803	C8	JMP14	D5	L901	C2	Q952	B4	R907	B3	R923A	A3	R967	B5	R984	D6	SW801	D8
C902	D2	C916	D2	C956	B5	C978	D5	C994	B4	CN952	D6	D958	D6	J804	C8	JMP15	D3	L951	A6	Q953	C6	R908	B3	R951	B6	R968	B5	R985	D5	SW802	A8
C902A	C1	C917	A2	C957	B6	C979	D5	C995	C6	D901	C3	D959	C5	J805	C8	JMP16	A1	L952	C7	Q954	C6	R910	D3	R952	B6	R969	B5	R986	D5	TR901	A4
C903	B2	C918	D1	C958	A4	C980	D6	C996	C5	D902	B3	D960	C5	J806	B8	JMP17	D5	L954	B5	Q955	C7	R911	D4	R953	B5	R971	D6	R987	D5	TR902	B4
C903A	B1	C919	D1	C959	C6	C981	B6	C997	D5	D903	B3	D962	D5	JMP1	A2	JMP18	C6	L955	D6	Q956	C6	R912	D4	R954	B5	R972	D6	R988	D4	TR903	C4
C904	A1	C920	D3	C960	C6	C982	A5	C998	C5	D904	A3	F901	C1	JMP2	B1	JMP19	B3	L956	C5	Q957	D7	R913	D3	R955	B5	R973	C7	R989	D7	TVR901	D1
C905	A1	C921	B2	C961	B5	C983	D7	C999	C4	D905	D3	GT901	C2	JMP4	C6	JMP20	D3	L957	D5	Q959	D6	R914	D2	R956	B6	R974	C6	R990	D7	ZD901	B3
C906	B2	C922	B2	C962	C7	C984	D7	CN803A	D8	D906	C3	IC901	D4	JMP5	C5	JMP21	D6	L958	C6	Q960	D6	R915	C3	R957	C6	R975	D6	R991	D6	ZD902	A3
C907	A2	C923	D4	C963	B5	C985	A6	CN804A	A8	D907	C4	IC902	D4	JMP6	D6	JMP22	C6	L959	D5	R1	D6	R916	C3	R958	A5	R976	D7	R992	D7	ZD903	C3
C908	A2	C926	B7	C964	B6	C986	A6	CN806A	B8	D908	D3	IC951	A5	JMP7	B7	JMP23	C7	L966	C5	R3	D3	R917	C4	R959	C6	R977	D7	R993	D7	ZD904	D4
C909	A3	C927	B7	C969	C5	C987	B7	CN807A	A8	D909	B4	IC952	A7	JMP8	C7	JMP24	B1	Q901	C3	R902	B2	R918	C3	R960	B6	R978	C6	R994	D7	ZD905	D3
C909A	A3	C928	B3	C970	D5	C988	A5	CN808A	B8	D910	B4	IC953	C6	JMP9	B7	JMP25	B1	Q902	B3	R903	A1	R919	C3	R961	B6	R979	C5	R995	C2	ZD951	B6
C911	D3	C951	B7	C972	D6	C989	B4	CN810A	C8	D951	B5	IC954	C5	JMP10	B3	JMP26	B1	Q903	D2	R904	B3	R920	D4	R962	C6	R980	D7	R996	B5	ZD953	C6
C912	D4	C952	B7	C973	C5	C990	D5	CN901	D1	D952	C6	IC955	D5	JMP11	C2	JMP27	C5	Q904	D3	R905	B3	R921	C3	R964	B4	R981	D7	R997	B5		

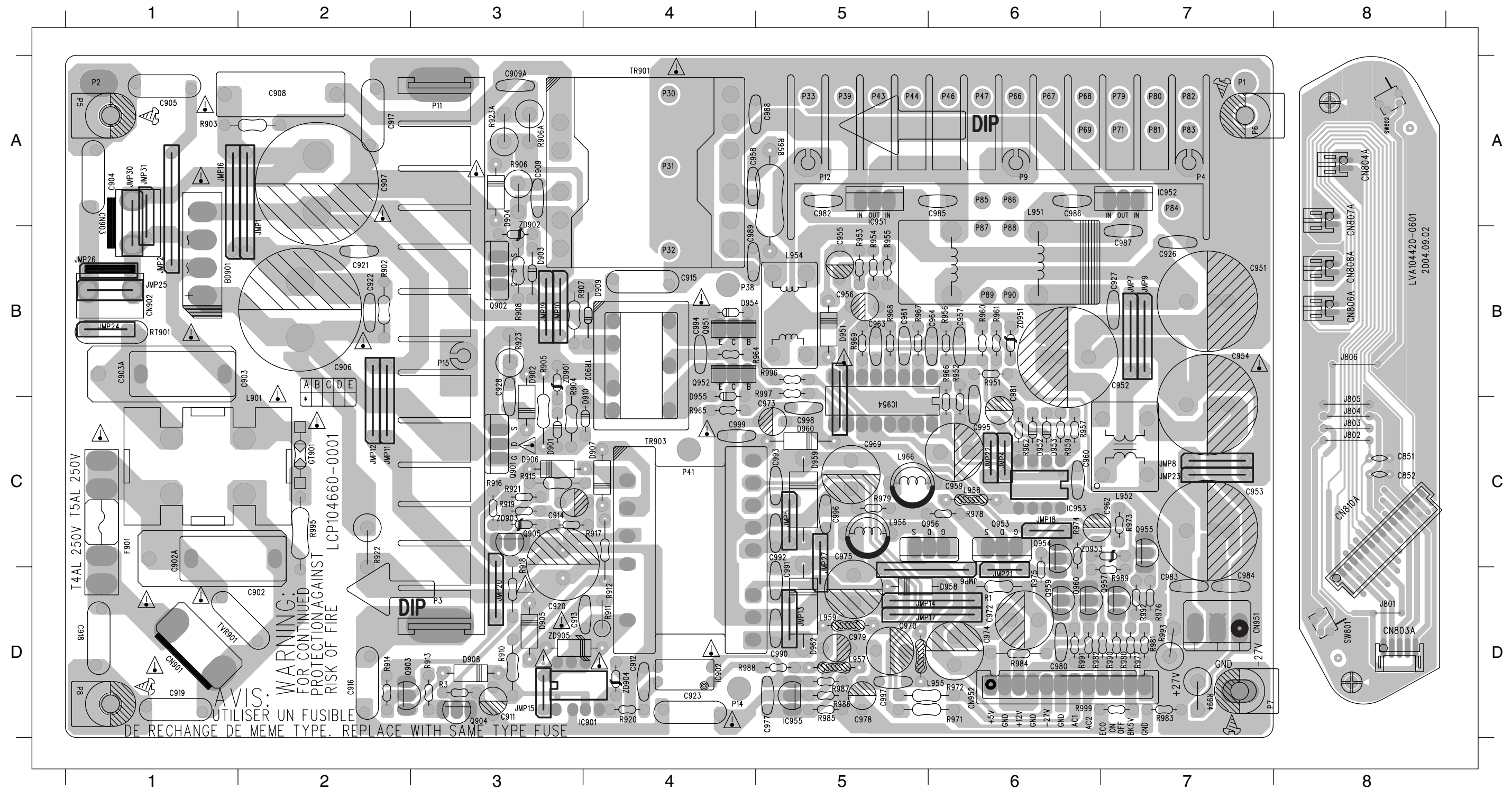

ELECTRIC PARTS - POWER BOARD

BD901	9940 000 00931	BRIDGE KBU808 8A 1000V	R972	△ 9940 000 00956	FUSE RES 5.6 1/4W 5%
C902	△ 9940 000 00932	COND SAFTY 0.47UF 275V 10%	RT901	9940 000 00957	NTC 5R 5A
C903	△ 9940 000 00932	COND SAFTY 0.47UF 275V 10%	TR901	△ 9940 000 00958	SW. MODEL TRANSFORMER
C908	9940 000 00933	COND METAL 1.5UF 250V +/-10%	TR902	△ 9940 000 00959	SW. MODEL TRANSFORMER
C915	△ 9940 000 00934	COND SAFTY 0.0022UF 400V 20%	TR903	△ 9940 000 00961	SW. MODEL TRANSFORMER
C916	△ 9940 000 00934	COND SAFTY 0.0022UF 400V 20%	TVR901	9940 000 00962	PTC THERMISTOR 50A 561V
C917	△ 9940 000 00934	COND SAFTY 0.0022UF 400V 20%	ZD905	9940 000 00963	DIODE P6KE200A
C918	△ 9940 000 00935	COND SAFTY 0.001UF 250V 20%			
C919	△ 9940 000 00935	COND SAFTY 0.001UF 250V 20%			
C923	△ 9940 000 00935	COND SAFTY 0.001UF 250V 20%			
C985	9940 000 00936	COND DISC 470PF 1KV 10%			
C986	9940 000 00936	COND DISC 470PF 1KV 10%			
C987	9940 000 00936	COND DISC 470PF 1KV 10%			
C988	9940 000 00936	COND DISC 470PF 1KV 10%			
C989	9940 000 00936	COND DISC 470PF 1KV 10%			
C990	9940 000 00936	COND DISC 470PF 1KV 10%			
C991	9940 000 00936	COND DISC 470PF 1KV 10%			
C992	9940 000 00936	COND DISC 470PF 1KV 10%			
C993	9940 000 00936	COND DISC 470PF 1KV 10%			
C994	9940 000 00937	COND DISC 220PF 1KV 10%			
C996	9940 000 00937	COND DISC 220PF 1KV 10%			
C999	9940 000 00936	COND DISC 470PF 1KV 10%			
D902	9940 000 00938	DIODE PR1507 1.5A 1000V			
D904	9940 000 00938	DIODE PR1507 1.5A 1000V			
D905	4822 130 11044	POWER RECTIFIER BYV26D			
D906	9940 000 00941	DIODE HER104 1A 300V 50NS			
D907	9940 000 00941	DIODE HER104 1A 300V 50NS			
D908	9940 000 00941	DIODE HER104 1A 300V 50NS			
D951	9965 000 09537	DIODE FR107 (CHENMKO) 1A/1000V			
D959	9940 000 00943	DIODE UF3003 3A 200V			
D960	9940 000 00941	DIODE HER104 1A 300V 50NS			
F901	△ 9940 000 00944	FUSE 4A 250V SLOW			
IC901	9940 000 00945	IC 8PIN KA5M02659RN			
IC902	9940 000 00946	OPTICAL SENSOR 4P			
IC951	9940 000 00947	BRIDGE MUR1620CT 8A 200V			
IC952	9940 000 00948	RECTIFIER FEP16AT TO-220AB			
IC953	9940 000 00949	IC 8PIN JRC4558D			
IC954	9940 000 00951	IC 16PIN KA7500C			
IC955	9940 000 00952	IC 3PIN TL431			
L901	9940 000 00953	AC FILTER 25MH			
Q901	9940 000 00954	MOSFET FQP18N50V2			
Q902	9940 000 00954	MOSFET FQP18N50V2			
Q953	9940 000 00955	MOS/FET STP60NF06 60A			
Q956	9940 000 00955	MOS/FET STP60NF06 60A			
R971	△ 9940 000 00956	FUSE RES 5.6 1/4W 5%			

Note: Only these parts mentioned in the list are normal service parts.

MECHANICAL EXPLODED VIEW

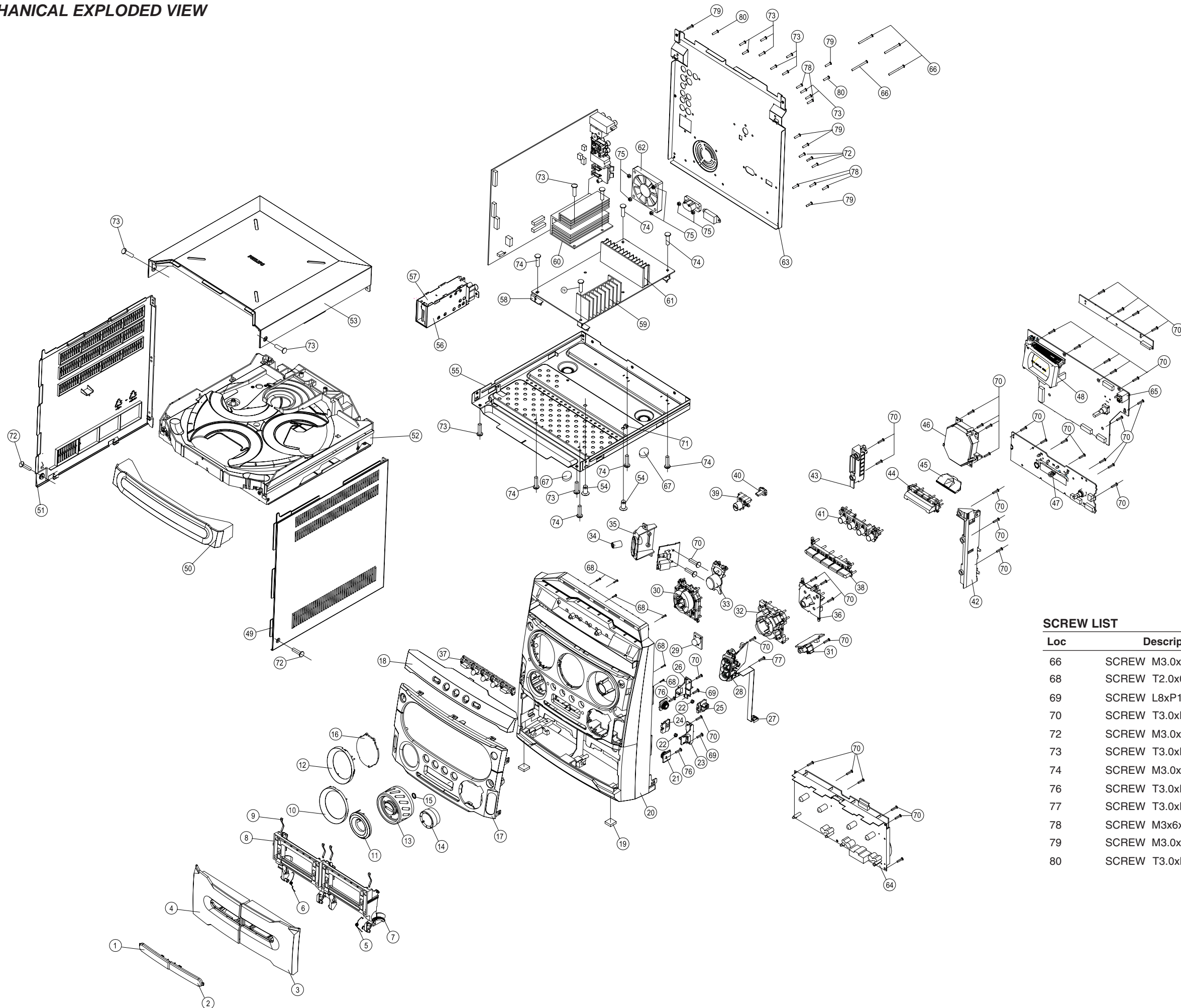

SCREW LIST

Loc	Description
66	SCREW M3.0xP0.5x22mm
68	SCREW T2.0x0.63PxL7mm
69	SCREW L8xP1.06xT3.0mm D=7.5mm
70	SCREW T3.0xL8xP1.06mm,0.47g
72	SCREW M3.0xP0.5x8
73	SCREW T3.0xL8xP1.06mm
74	SCREW M3.0xP0.5x6,0.5g
76	SCREW T3.0xL8.0xW/@10.0mm
77	SCREW T3.0xL10xP1.06mm
78	SCREW M3x6x0.5P
79	SCREW M3.0xP0.5x10
80	SCREW T3.0xL10xP1.06mm

MECHANICAL & ACCESSORIES PARTS

1	9940 000 00909	LENS CASS. (L)	9940 000 00916	MAIN SPK. ASSY 100WX2 3R
2	9940 000 00911	LENS CASS. (R)	9940 000 00918	FFC CABLE 14P 220MM
3	9940 000 00908	COV. DOOR CASS	9940 000 00919	FFC CABLE 24P 380MM
4	9940 000 00906	COV. DOOR CASS(L)	9940 000 00925	LOOP ANT W/2P 2.5MM
5	9965 000 22200	SPRING TWIST (R)	9940 000 00928	REMOTE CONTROL 45KEY
6	9965 000 22201	SPRING TWIST (L)	9940 000 00929	PICK UP ASS'Y HITACHI
7	9965 000 22173	DOOR CASSETTE-RIGHT	9965 000 14636	RCA CABLE 1200MM OD2.6x5.2
8	9965 000 22172	DOOR CASSETTE LEFT	9965 000 20234	RCA CABLE 1500MM OD2.6x7.8
9	9965 000 22205	SPRING CASSETTE	9965 000 20577	RCA CABLE 1500MM OD2.6x5.2
10	9940 000 00902	COVER VU METER	9965 000 23583	FM ANTENNA 1000MM
11	9940 000 00883	CAP KNOB VOLUME	△ 9965 000 24688	LINE CORD 2P 2000MM BLK
12	9940 000 00901	COVER VFD		
13	9940 000 00891	KNOB VOLUME		
14	9940 000 00884	KNOB ROTARY		
16	9940 000 00904	WINDOW DISPLAY		
17	9940 000 00875	PANEL FRONT DISPLAY		
18	9940 000 00897	FRONT CDC		
19	9965 000 22119	FOOT RUBBER		
20	9940 000 00898	FRONT CABINET		
21	9965 000 22120	DAMPER-ASSY-MODULE-0.8		
24	9965 000 22141	PUSH CATCH RIGHT		
25	9965 000 22140	PUSH CATCH-LEFT		
30	9940 000 00895	BUT CNTL(3)		
32	9940 000 00893	BUT.CONT(1)		
33	9940 000 00894	BUT.CNTL(2)		
34	9940 000 00876	KARAOKE KNOB D10.2X15.5		
37	9940 000 00887	BUTTON DISC SELECT		
38	9940 000 00892	BUTTON CASS		
39	9940 000 00888	BUTTON POWER STANDBY		
41	9940 000 00889	BUTTON SOURCE(MAX)		
44	9940 000 00896	BUTTON MAX-WOOX		
49	9940 000 00913	PANEL RIGHT		
50	9940 000 00903	COVER CDC		
51	9940 000 00912	PANEL LEFT		
52	9940 000 00874	3 CDC MODULE		
56	9940 000 00873	TUNER MODULE		
62 △	9940 000 00917	FAN 60X60X15MM DC 12V		
64	9940 000 00927	TAPE DECK PHILIPS		
67	9940 000 00877	RUBBER DIA14XT2MM BLACK		
73	9940 000 00899	COVER TOP		

Note: Only these parts mentioned in the list are normal service parts.